



FUEL MANAGEMENT SYSTEMS



DISPENSERS



KITS



PUMPS



METERS



NOZZLES

ST WITH METER AND FILTER

FEATURES

- **READY TO USE**
- **VERSATILE**
- **EASY TO INSTALL**
- **COMPACT DESIGN**
- **FILTRATION GUARANTEED**
- **AVAILABLE WITH DIFFERENT PUMPS**

PIUSI ST WITH METER AND FILTER is a range of dispensers particularly suited for all applications in which a filtration is required. The stations integrate PIUSI CLEAR or WATER CAPTOR FILTERS and are available with mechanical meter K33 or electronic meter K24/K600 B/3. They come with integrated check valve and 4-meter delivery hose.

PERFORMANCE

UP TO

90 L/MIN

FLOW RATE

AC

CONTINUOUS DUTY

POWER

± 1%

ACCURACY

UP TO

6MT

LENGTH

DELIVERY HOSE

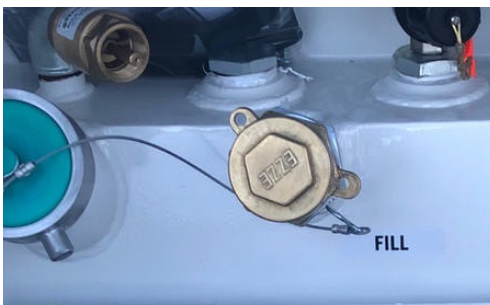

FILL



ST PANTHER 56, K33, A60 AND WATER CAPTOR



ST PANTHER 56, K33, A60 AND CLEAR CAPTOR

PACKAGING

CODE	WEIGHT		PACKAGING		
	KG	LBS	MM	INCH	PCS/BOX
FOO386FOA	25	55	580X380X320	22,8X15X12,6	1
FOO265FOA	26	57	580X380X320	22,8X15X12,6	1
FOO395FOA	32	71	545X435X340	21,5X17,1X13,4	1
FOO386F6O	22	48	380X380X480	15X15X18,9	1
FOO386R7O	22	48	380X380X480	15X15X18,9	1
FOO265F4O	26	57	580X380X320	22,8X15X12,6	1
FOO265S8O	26	57	580X380X320	22,8X15X12,6	1
FOO395F6O	32	71	545X435X340	21,5X17,1X13,4	1
FOO265S2O	18	40	480X370X260	18,9X14,6X10,2	1
FOO265R7O	18	40	480X370X260	18,9X14,6X10,2	1



FILTRATION



TANK MONITORING



HOSE REEL



ACCESSORIES



MERCHANDISE



AIR



ANTIFREEZE



AdBlue®



BIODIESEL



DIESEL



FOOD



GASOLINE



GREASE



KEROSENE



OIL



WATER



WINDSCREEN

AVAILABLE WITH DIFFERENT PUMPS AND METERS



AC PUMP - PANTHER 56/72

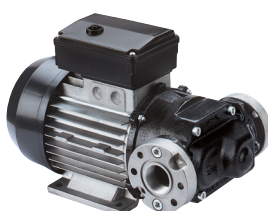

AC PUMP - E120



AUTOMATIC NOZZLE



MECHANICAL METER - K33



ELECTRONIC METER - K24



K600 B/3

DIMENSIONS

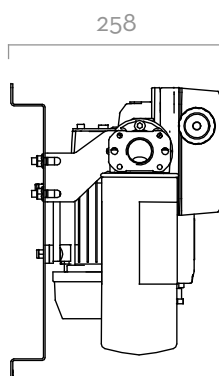
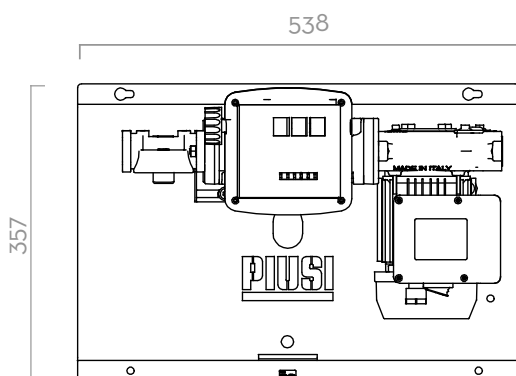

Dimensions expressed in millimeters

IN THE BOX

- ST WITH METER AND FILTER
- METER
- FILTER
- DELIVERY HOSE
- NOZZLE
- NOZZLE HOLDER
- INSTRUCTION MANUAL

DETAILS



WATER CAPTOR FILTER (pag. 170)



MAN. / AUTOM. NOZZLE



K24 / K600 B/3 METER



K33 METER

COMPONENTS

- PUMPS:
PANTHER AC PAG. 102
E80/E120 PAG. 106
- NOZZLE:
AUTOMATIC NOZZLE PAG. 158
- METER:
K33 PAG. 146
K24 PAG. 132
K600 B/3 PAG. 136
- FILTER
WATER CAPTOR PAG. 170

TECHNICAL DATA

CODE	DESCRIPTION	FLUIDS TYPE	FLOW RATE		VOLTAGE			METER	NOZZLE	FILTER	DELIVERY HOSE		SUCTION HOSE		INLET
			L/MIN	GPM	AC V/Hz	DC VOLT	POWER WATT				AMP. MAX.	LENGTH	Ø	LENGTH	
FO0386FOA	ST PANTHER 56 FILTER + A60	D	52	14	230/50	350	3	K33	A60	YES	6M	3/4"	4M	1"	
FO0265FOA	ST PANTHER 72 FILTER + A60	D	70	18	230/50	500	4,2	K33	A60	YES	6M	3/4"	4M	1"	
FO0395FOA	ST E120 FILTER + A120	D	85	22	230/50	1150	5,7	K33	A120	YES	6M	1"	4M	1"	
FO0386F60	ST PANTHER 56 FILTER + A60	D	52	14	230/50	350	3	K33	A60	YES	6M	3/4"	-	-	
FO0386R70	ST PANTHER 56 + CLEAR CAPTOR + A60	D	52	14	230/50	350	3	K33	A60	YES	6M	3/4"	-	-	
FO0265F40	ST PANTHER 72 FILTER + A60	D	70	18	230/50	500	4,2	K33	A60	YES	6M	3/4"	-	-	
FO0265S80	ST PANTHER 72 K600 B/F/6T/PA60	D	70	18	230/50	500	4,2	K600 B/3	A60	YES	6M	1"	-	-	
FO0395F60	ST E 120 FILTER + A120	D	85	22	230/50	1150	5,7	K33	A120	YES	6M	1"	-	-	
FO0265S20	ST PANTHER 72 FILTER + K24 METER	D	70	18	230/50	500	4,2	K24	A80	YES	6M	3/4"	-	-	
FO0265R70	ST PANTHER 72 + CLEAR CAPTOR + A80	D	70	18	230/50	500	4,2	K24	A80	YES	6M	1"	-	-	

ST WITH METER AND FILTER