

Part Number: S312B1101B



© Copyright MannTek / ELAFLEX HIBY

Product Group

Dry Disconnect Couplings

Quick and safe connection of hose assemblies and loading arms to mobile and stationary tanks, under pressure and with minimised liquid loss.

The standardised interface to STANAG 3756 with its bayonet coupling principle has been widely accepted in the industry. Both coupling parts are equipped with a flat poppet valve.

For the connection, the hose unit is pushed onto the tank unit and coupled / sealed by turning the coupler clockwise by 15 degrees. When the unit is turned by 100 degrees, the valves move into the tank unit so that the medium can flow. When a similar turn is made counter-clockwise, the flow is stopped and the coupler can be pulled off.

Certificates: DDC couplings fulfill the requirements of European Pressure Equipment Directive category 2 (for higher demand on request).

They are suitable for the use in potentially explosive atmosphere (ATEX) zone 1, approved for the transport of dangerous goods on road (ADR), by rail (RID) and by ship (IMDG), specified as a branch standard from European Chemical Industry (CEFIC) for handling of Ethylene Oxide/Propylene Oxide, Acrylic Monomers, Acrylonitrile, polymeric MDI/TDI and Vinyl Chloride.

TÜV TÜ.AGG 304-99, APRAGAZ File ref. 0302/P5832, Lloyd's Register 0038/ATEX/HAM064017,

TDT-UW-21/16, EAC TC No. RU Д-SE.MЮ62.B.02151

Type of Coupling

Female (Hose Unit, Coupler)

Self locking quick connect/disconnect coupling, to STANAG 3756, for liquid media. Hose unit with swivel, typically mounted on hose assemblies and loading arms for temporary connection to storage tanks and mobile transport units, for loading and unloading.

Configurator MannTek Products

Quick and safe connection of hose assemblies and loading arms to mobile and stationary tanks, under pressure and with minimised liquid loss.

The standardised interface to STANAG 3756 with its bayonet coupling principle has been widely accepted in the industry. Both coupling parts are equipped with a flat poppet valve.

For the connection, the hose unit is pushed onto the tank unit and coupled / sealed by turning the coupler clockwise by 15 degrees. When the unit is turned by 100 degrees, the valves move into the tank unit so that the medium can flow. When a similar turn is made counter-clockwise, the flow is stopped and the coupler can be pulled off.

Nominal Diameter /
Socket Diameter

2½" (Ø 105 mm)

Recommended for road tanker bottom loading for a variety of fluids, ISO containers, Aviation fuel bunkering or on any application where product contamination and spillage needs to be minimized.

Body Material

Aluminium

Maximum Working Pressure 10 bar

Test Pressure 15 bar

Minimum Burst Pressure 50 bar

Connection

Threaded Connection

Connection Detail

F 2½" BSP

2½" BSP female to EN ISO 228

Connection Detail

Technical Drawing

O-Rings

Viton® (FPM/FKM) Standard

FKM/FPM (Fluorocarbon Rubber): FKM is known especially for its non-flammability, low gas permeability and excellent resistance to ozone, weathering and aging.

The operating temperatures of the Fluorocarbon Rubber range between -20° C and +200° C).

FKM is often used with mineral based oils and greases at high temperatures, aliphatic, aromatic and chlorinated hydrocarbons and oxidizing acids.

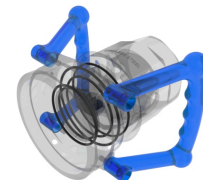

Options: Special Types

No Special Types required

Options: Handle

Standard



Options: Selectivity

No Selectivity

Options: Selectivity
System

Without Selectivity System

Flat Seal

Polyurethane (Default)

Accessories

Without

Notice: This drawing contains proprietary information and shall not be used or reproduced or its contents disclosed in whole or in part, without the prior written consent of the Mann Teknik AB

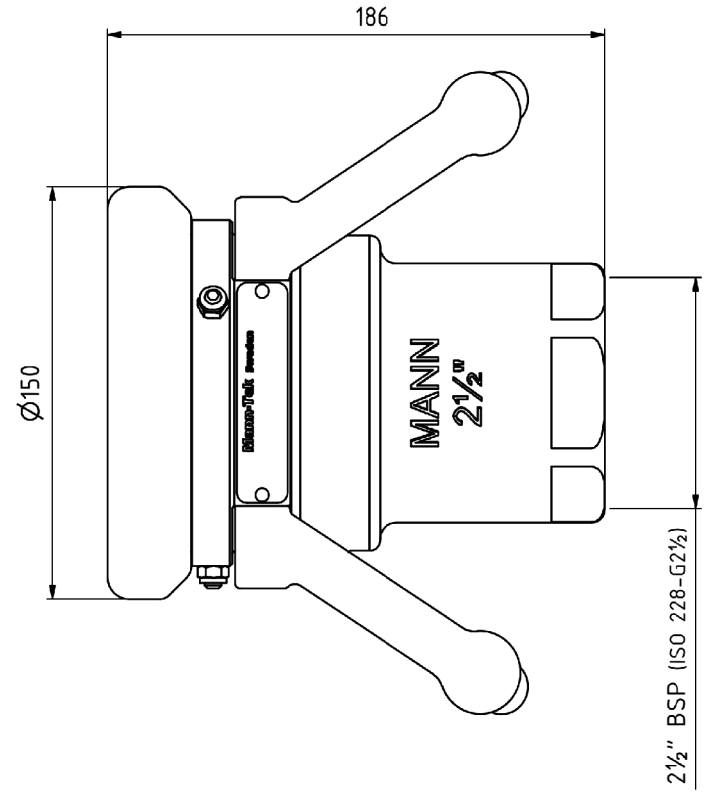
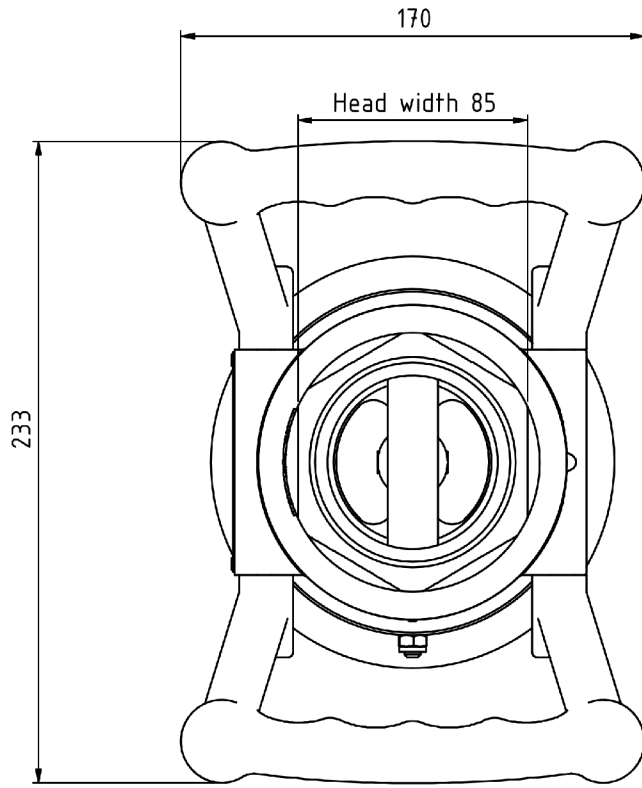

MannTek

S312B1101B-1
Dry Disconnect Couplings
2 1/2" (Ø 105 mm)
F 2 1/2" BSP