

FPO 80

Tank truck vane pump



Alfons Haar

Operating instructions

**FPOD, FPOG, FPOJ,
FPON, FPOS 80 - ...**



II 2G cT3



Index	Page
Proper use	2
Type code	3
Technical data	4
Application notes	4
Dimensions	5
Flow charts	9
Input power charts	10
Net positive suction head	11
Bypass valve control	12
Flow control	12
Installation	13
Start-up	19
Maintenance	20
Troubleshooting	20

FPOD, FPOG, FPOJ, FPON, FPOS 80 - ...

Proper use



People and material may be put at risk in the event of any deviation from the intended form of application. The limits contained in these instructions may not be exceeded.

The vane pump is used to pump low-viscosity mineral oil products and non-corrosive and/or suspension-free liquids up to a viscosity of approx. 76 cSt (up to 500 cSt with positive actuation of the vanes). It is resistant against E 85, bio diesel and vegetable oil and is suitable for installation in zone 1 according CD 1999/92/EG.

Measures for explosion proofness:

These operating instructions describe the necessary measures for safe operation (e.g. prevention of excessive temperature, excessive run time of dry pumping).

If this can not be assured, additional measures shall be taken (e.g. deactivation by temperature switch, safeguarding the connected systems by flame arrestors).

Each modification of the vane pump and every alteration of the use, that was arranged at the sale, requires consultation with Alfons Haar.

FPOD, FPOG, FPOJ, FPON, FPOS 80 - ...



Type code	FPO	CH	D	80	-	700	Z	R	X1	-	PA	1.8
<p><u>Vane type pump</u> with connections on top for vertical installation position, integrated by-pass valve</p> <p><u>Usage</u> w/o: Standard (for mineral oil, E 85, bio diesel and vegetable oil) CH: for solvents</p> <p><u>Shaft design (dimensional)</u> D: Free cylindrical drive-shaft end with feather key on both side (special design) G*: Free cylindrical drive-shaft end with feather key and drive-shaft end for hydraulic pump HyZFS J: Shaft end for drive with hydraulic motor MZFS N**: both shaft ends for drive with two hydraulic motors MZFS S: Shaft end with internal toothing for HyPOWER motor</p> <p><u>Nominal bore of suction and discharge side</u></p> <p><u>Theoretical volumetric flow</u> (Litres / 1000 rotations or cm³ / rotations)</p> <p><u>Positive actuation of the vanes</u> w/o: without positive actuation Z: with positive actuation of 6 vanes</p> <p><u>Direction of rotation (as seen on drive-shaft)</u> R: Clockwise directional rotation L: Counterclockwise directional rotation</p> <p><u>Operation temperature range</u> V: -15 to +70°C (standard) X1: -32 to +70°C (low temperature)</p> <p><u>By-pass valve</u> P: pneumatic M: mechanical</p> <p><u>Pump pressure (depending on pressure spring in the by-pass valve)</u> pneumatic (e.g.): (PA) 1.8: By-pass valve with pressure spring 1.8 bar (PB) 3.0: By-pass valve with pressure spring 3.0 bar</p> <p>mechanical (fixed setting): (MC) 3.5: By-pass valve with pressure spring 3.5 bar (MC) 6.5: By-pass valve with pressure spring 6.5 bar (MC) 8.0: By-pass valve with pressure spring 8.0 bar (MC) 10.0: By-pass valve with pressure spring 10.0 bar</p>												

* Shaft design G replaces shaft design C

** Shaft design N only with positive actuation of the vanes

FPOD, FPOG, FPOJ, FPON, FPOS 80 - ...

Technical data

Speed:	n_{\max}	= 1500 rpm
	n_{\min}	= 500 rpm
with pos. actuation of vanes:	n_{\min}	= < 500 rpm
Viscosity:	v_{\max}	= 76 cSt
with pos. actuation:	v_{\max}	= 500 cSt (higher viscosity on request)
Nominal pressure:	PN	= 10 bar
Max. pressure difference (continuous operation)	Δp	= 10 bar
Temperature range: (Temperatures up to -32 °C and in excess of 70 °C in consultation with Alfons Haar)	t	= - 15 °C to + 70 °C
Operating pressure (Pneumatic)		= 3 to 5 bar

Application notes

- Installation position: The shaft of the pump is to be positioned horizontally; the maximum permissible inclination is 5°. The housing can be aligned to suit; the pump can be installed upright or horizontally.
- Intake characteristic: Because of their very good intake characteristics, vane-type pumps are well suited for self-filling vehicles using underground tanks.
- Residual drainage: The special positive-displacement characteristics mean that it is possible to empty the system practically down to the measuring chamber volume level without using an additional discharge pump, e.g. when changing products.
- Pneum. control: The pneumatic control on the overflow valve can be used to influence the pump pressure and volumetric flow. (See: Bypass valve control)

FPOD, FPOG, FPOJ,
FPON, FPOS 80 - ...



Dimensions

FPOD 80- ... R - P ...

For other fitting positions:
Lubricating nipple must face upwards!
(unscrew cover, turn cover and fasten it again)

Attention: Do not remove the screws
at the bypass cover. Risk of accident!
Very strong pressure spring!

to remove housing cover:
Screw thread (M12)

* Connections "R" and "O":
Connect pneumatic tube OD 6,
length min. 300 mm. Lay tube
end to a protected and deeper
place (for "O" if it is not in use)

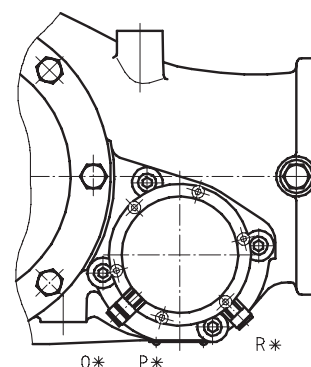
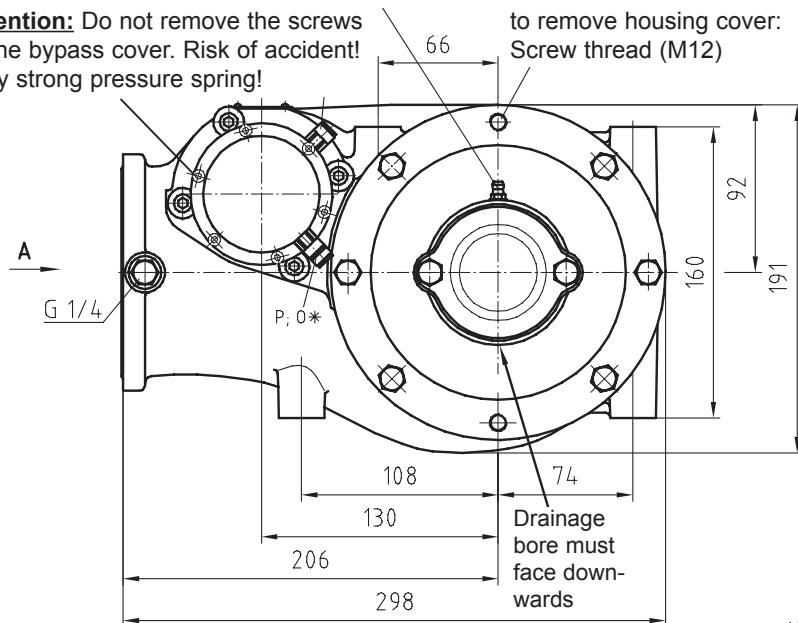

For this pump fitting position:
Loosen valve insert and fasten it
again in this position.

Weight: 38.2 kg

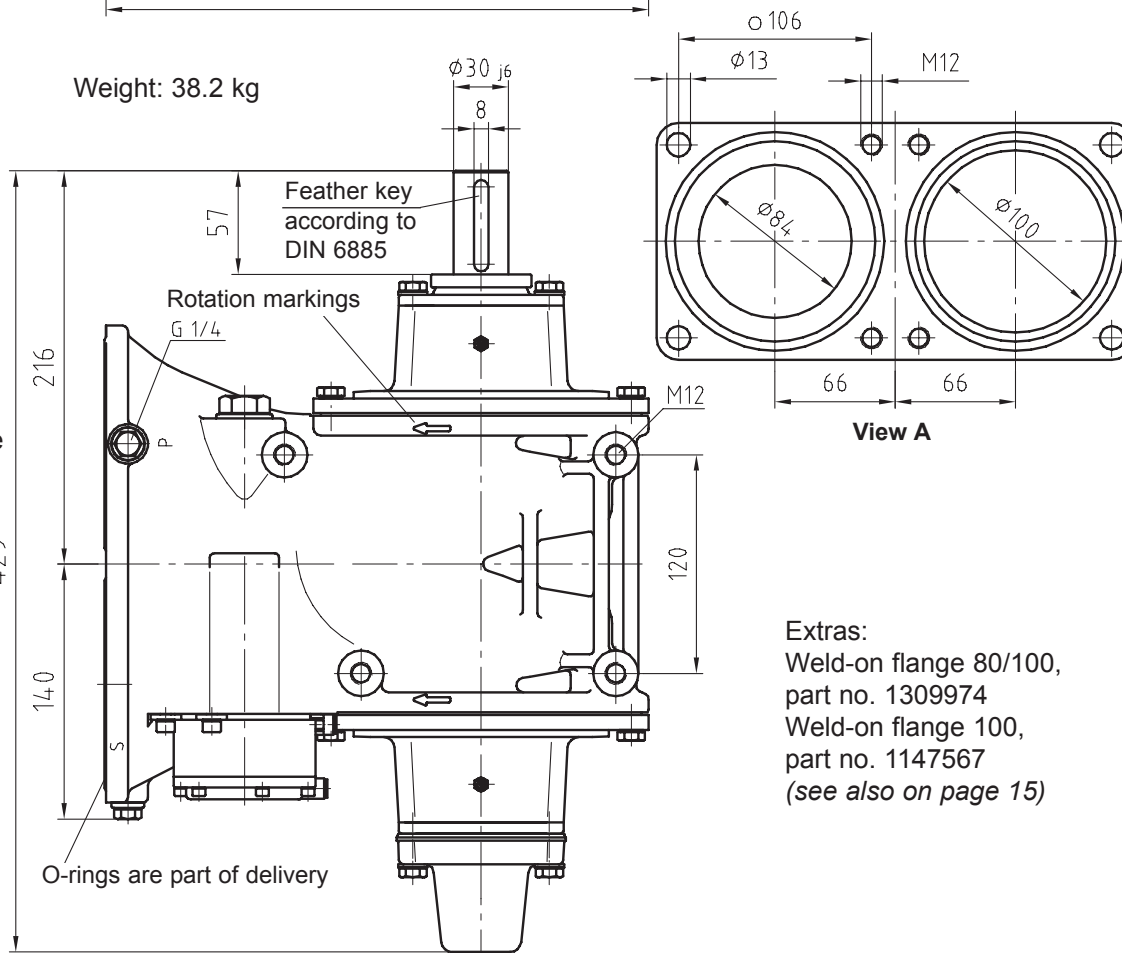

Extras:
Weld-on flange 80/100,
part no. 1309974
Weld-on flange 100,
part no. 1147567
(see also on page 15)

FPOD, FPOG, FPOJ, FPON, FPOS 80 - ...

FPOG 80- ... L - P ... -0 for hydraulic pump HyZFS 0/... L FPOG 80- ... R - P ... -0 for hydraulic pump HyZFS 0/... R

For other fitting positions: Lubricating nipple must face upwards!
(unscrew cover, turn cover and fasten it again)

* Connections "R" and "O":
Connect pneumatic tube OD 6,
length min. 300 mm. Lay tube
end to a protected and deeper
place (for "O" if it is not in use)

Attention: Do not remove the screws
at the bypass cover. Risk of accident!
Very strong pressure spring!

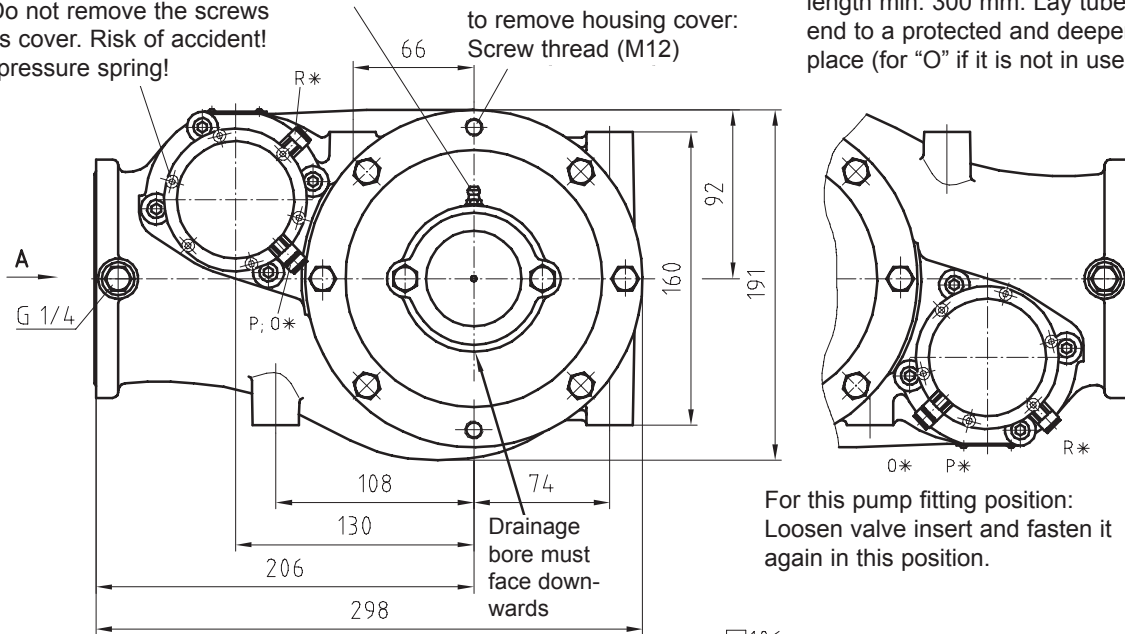

For this pump fitting position:
Loosen valve insert and fasten it
again in this position.

Type "R"
Shaft on this side

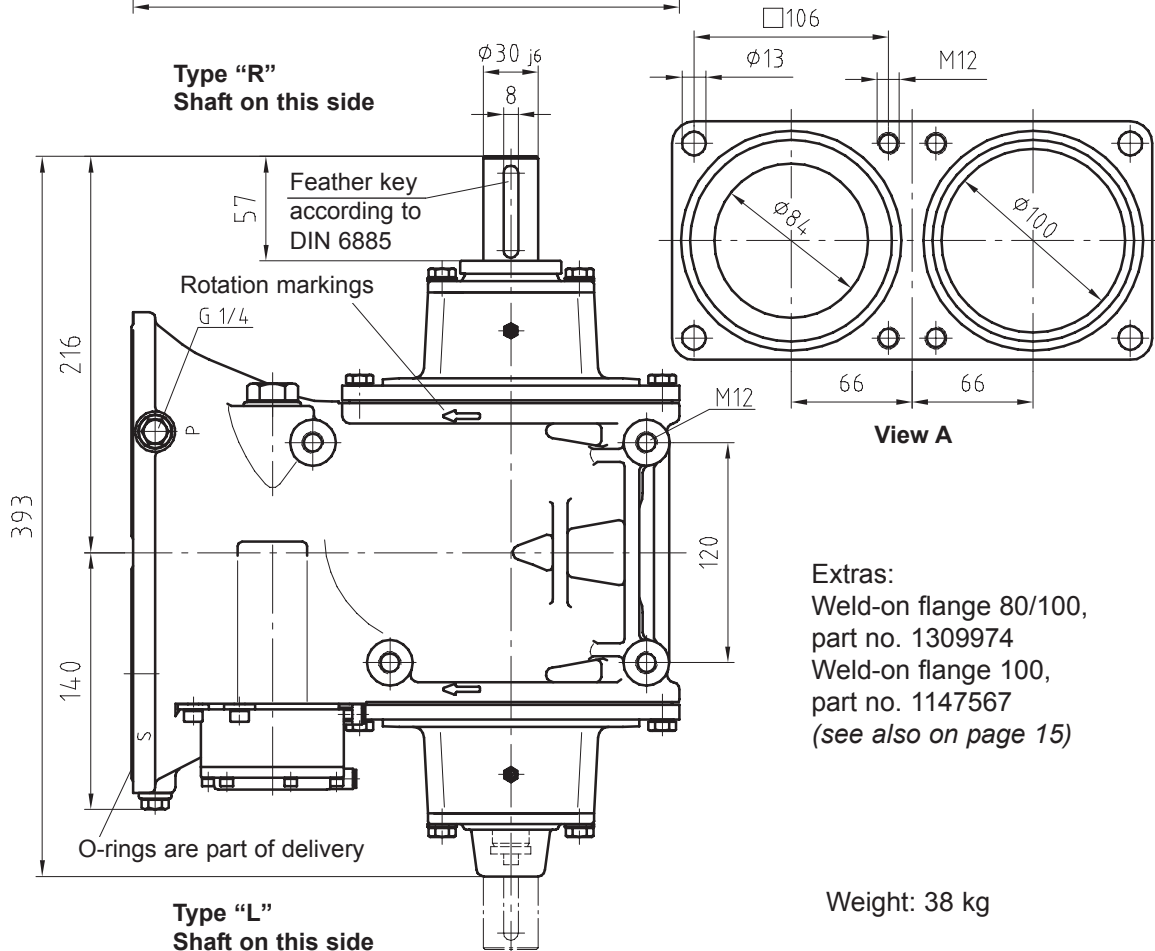

Extras:
Weld-on flange 80/100,
part no. 1309974
Weld-on flange 100,
part no. 1147567
(see also on page 15)

Weight: 38 kg

FPOD, FPOG, FPOJ, FPON, FPOS 80 - ...



FPOJ 80- ... R - P ... with MZFS 16L

For other fitting positions: Lubricating nipple must face upwards!
(unscrew cover, turn cover and fasten it again)

Attention: Do not remove the screws at the bypass cover. Risk of accident!
Very strong pressure spring!

* Connections "R" and "O":
Connect pneumatic tube OD 6,
length min. 300 mm. Lay tube
end to a protected and deeper
place (for "O" if it is not in use)

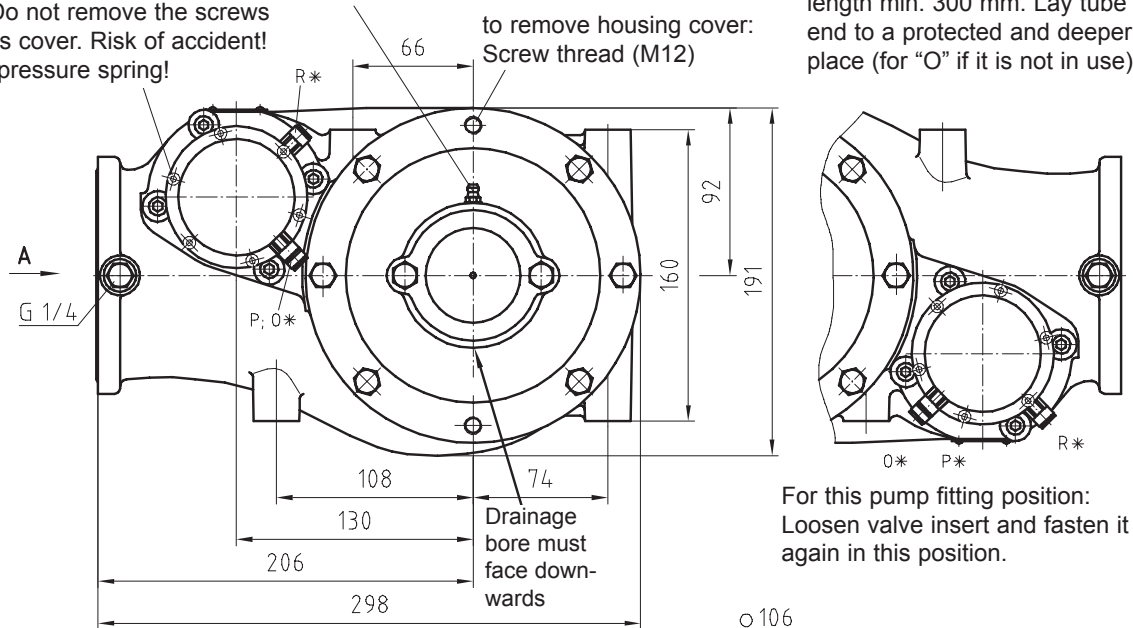

For this pump fitting position:
Loosen valve insert and fasten it
again in this position.

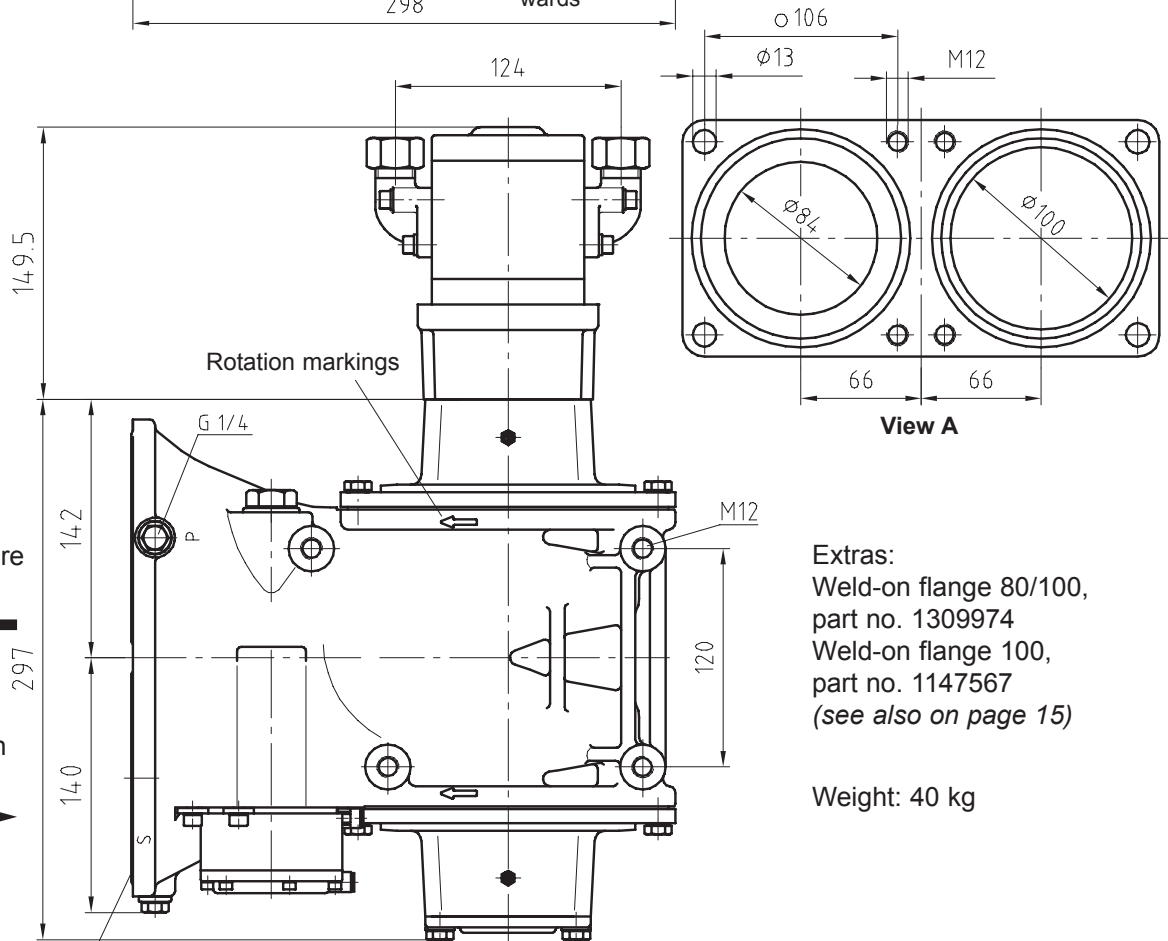

Extras:
Weld-on flange 80/100,
part no. 1309974
Weld-on flange 100,
part no. 1147567
(see also on page 15)

Weight: 40 kg

O-rings are part of delivery

FPOD, FPOG, FPOJ, FPON, FPOS 80 - ...

FPOS 80- ... R - P ... -0 with HyPOWER 47/64

For other fitting positions: Lubricating nipple must face upwards! (unscrew cover, turn cover and fasten it again)

to remove housing cover: Screw thread (M12)

* Connections "R" and "O": Connect pneumatic tube OD 6, length min. 300 mm. Lay tube end to a protected and deeper place (for "O" if it is not in use)

Attention: Do not remove the screws at the bypass cover. Risk of accident! Very strong pressure spring!

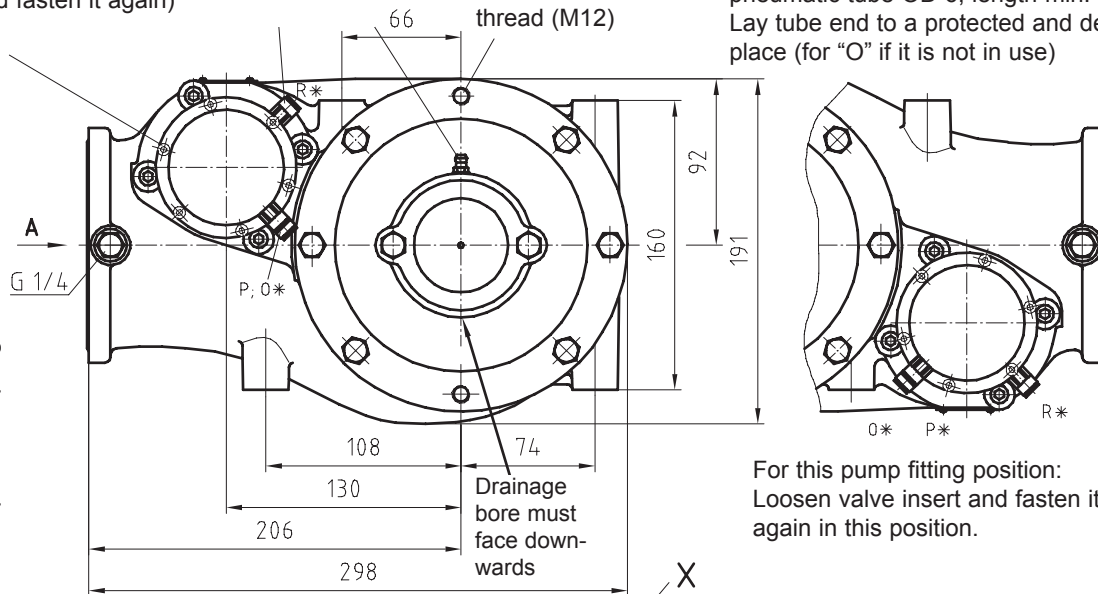

For this pump fitting position: Loosen valve insert and fasten it again in this position.

Motor turned by 45°
Motor can be mounted in 90° angles

Weight: 49.7 kg (with HyPOWER 47)
53 kg (with HyPOWER 64)

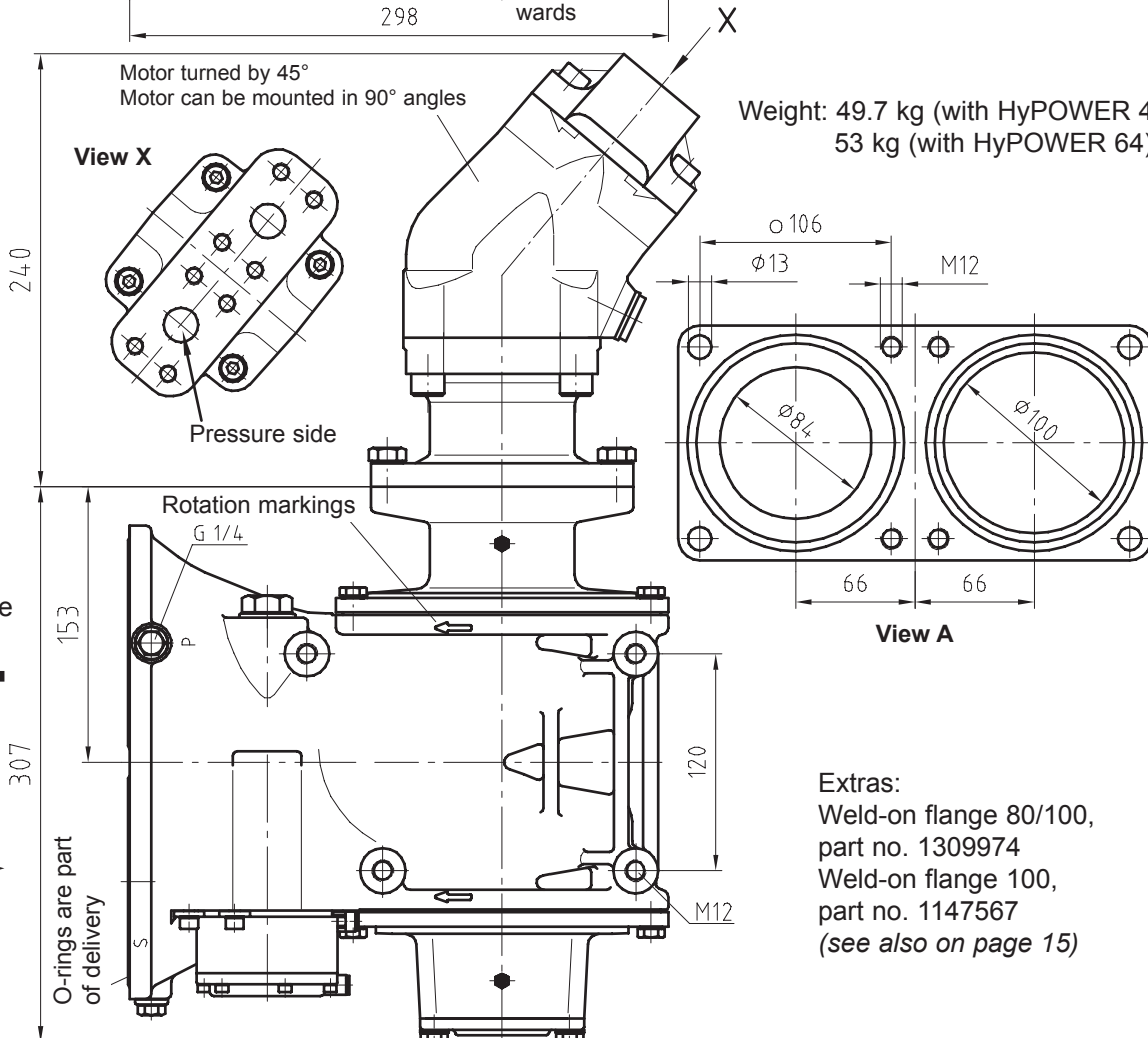

Extras:
Weld-on flange 80/100,
part no. 1309974
Weld-on flange 100,
part no. 1147567
(see also on page 15)

Flow rate charts

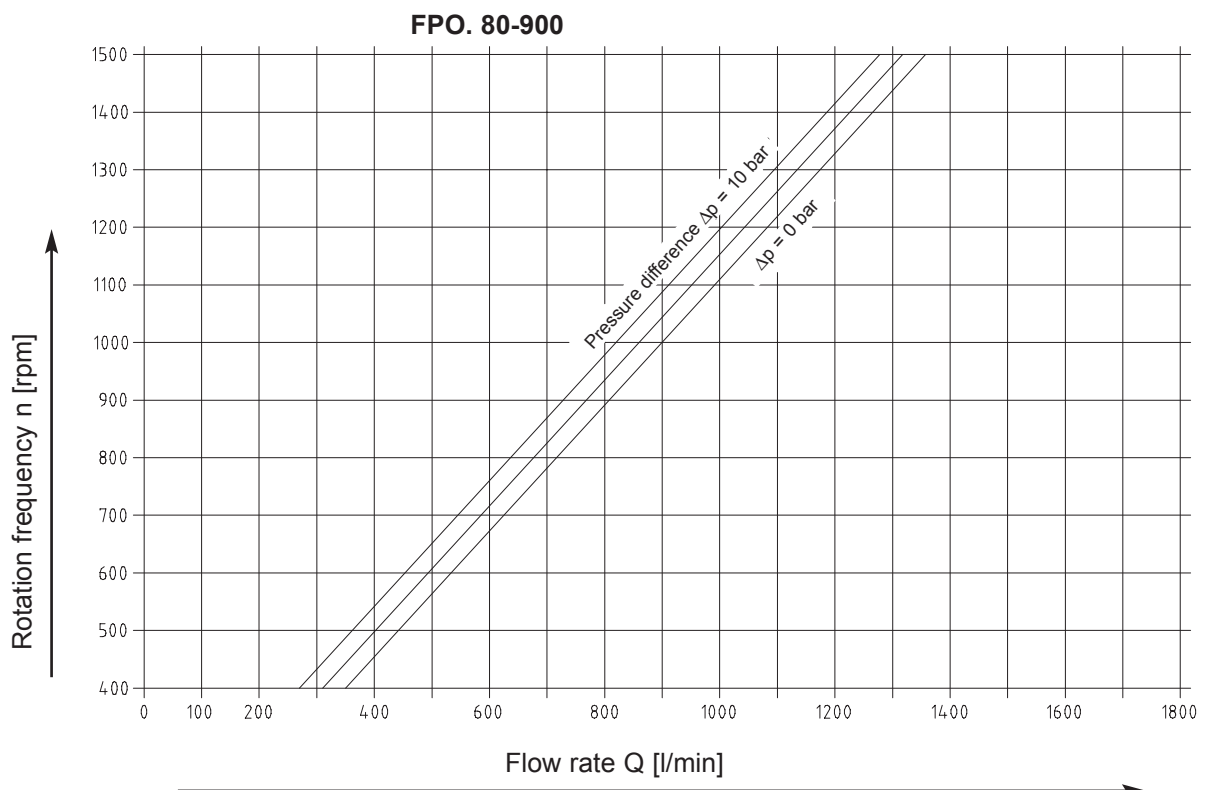
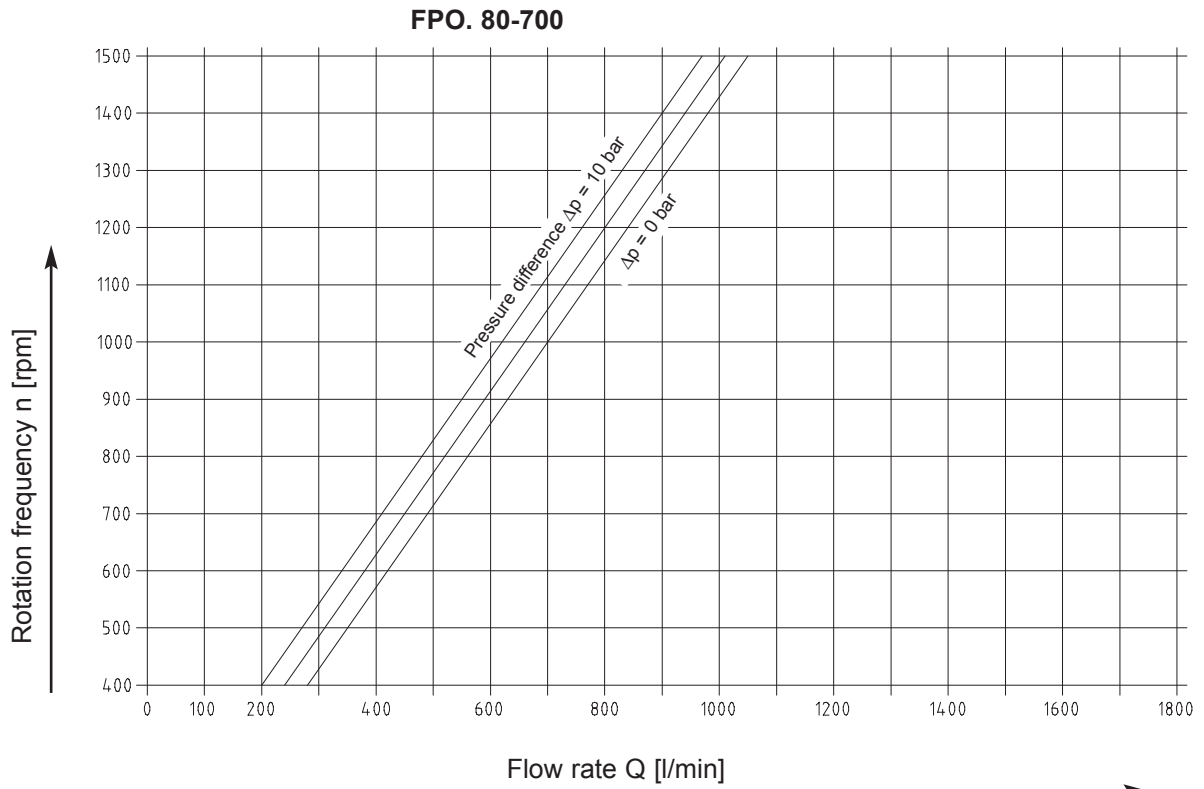

FPOD, FPOG, FPOJ, FPON, FPOS 80 - ...

Input power charts (P-p-n)

The input powers of the pump are minimum values for non-viscous media with viscosities up to approx. 12 cSt as e.g. heating oil EL, diesel and motor gasoline.

FPO. 80-700

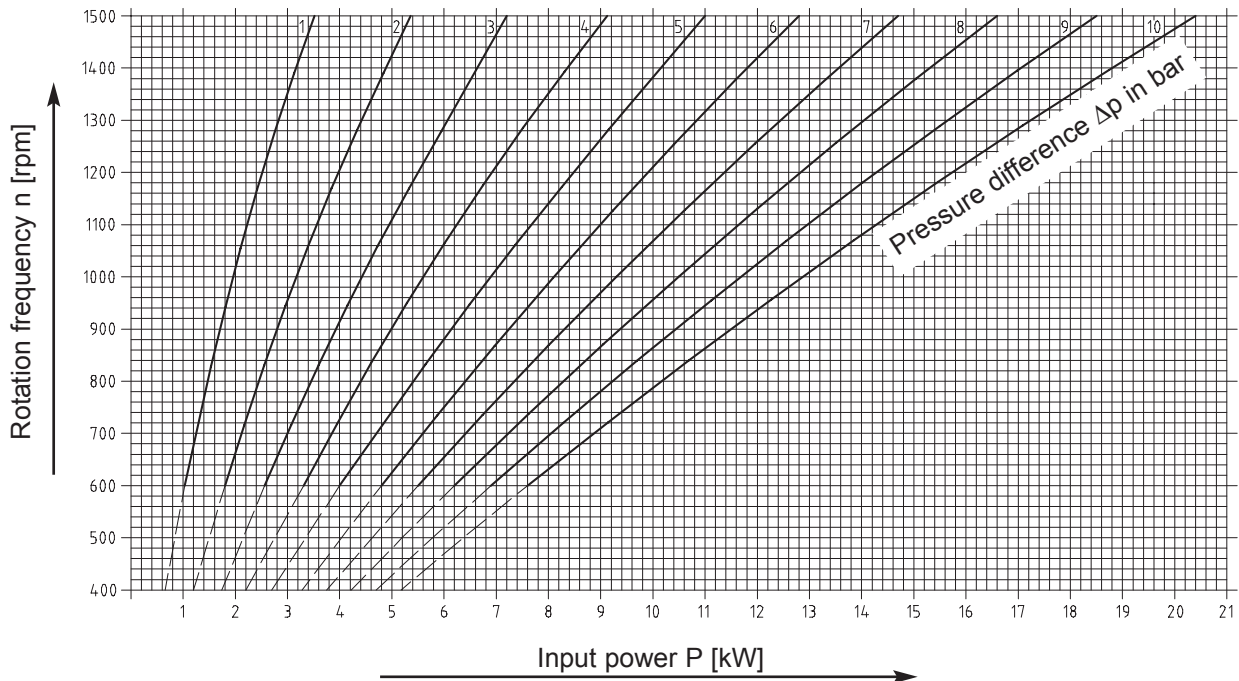

FPO. 80-900

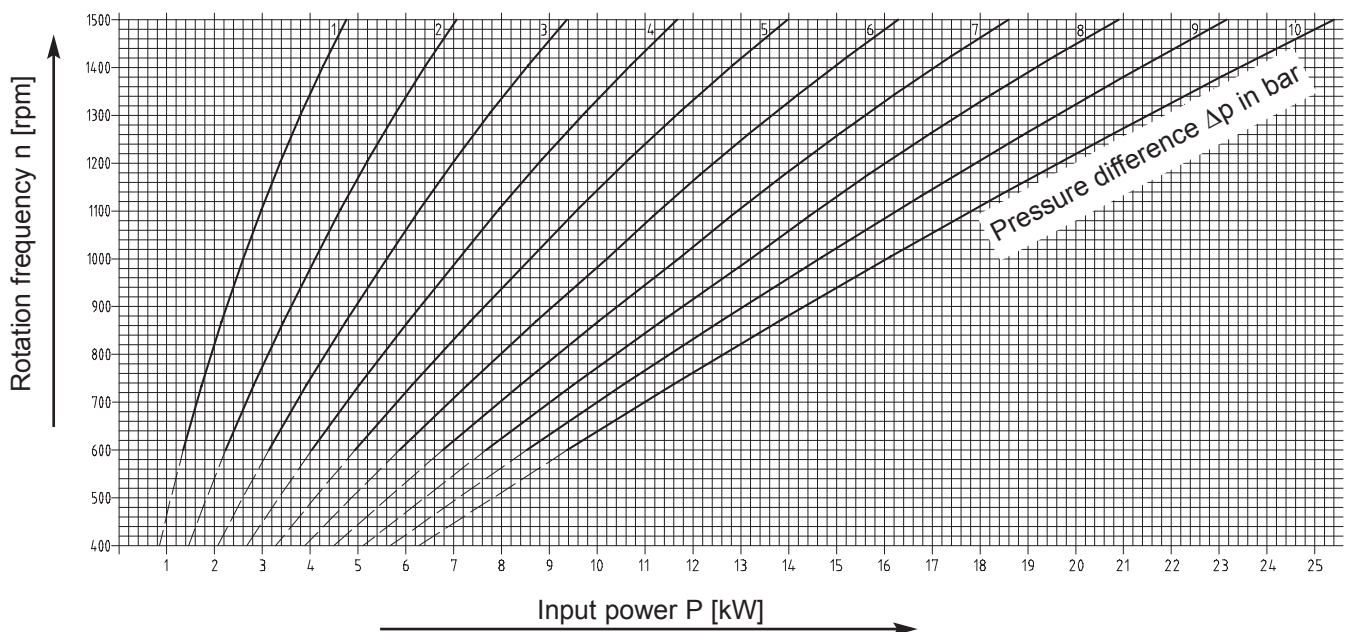

FPOD, FPOG, FPOJ,
FPON, FPOS 80 - ...



Net positive suction head

Viscosity of the medium: 12 cSt

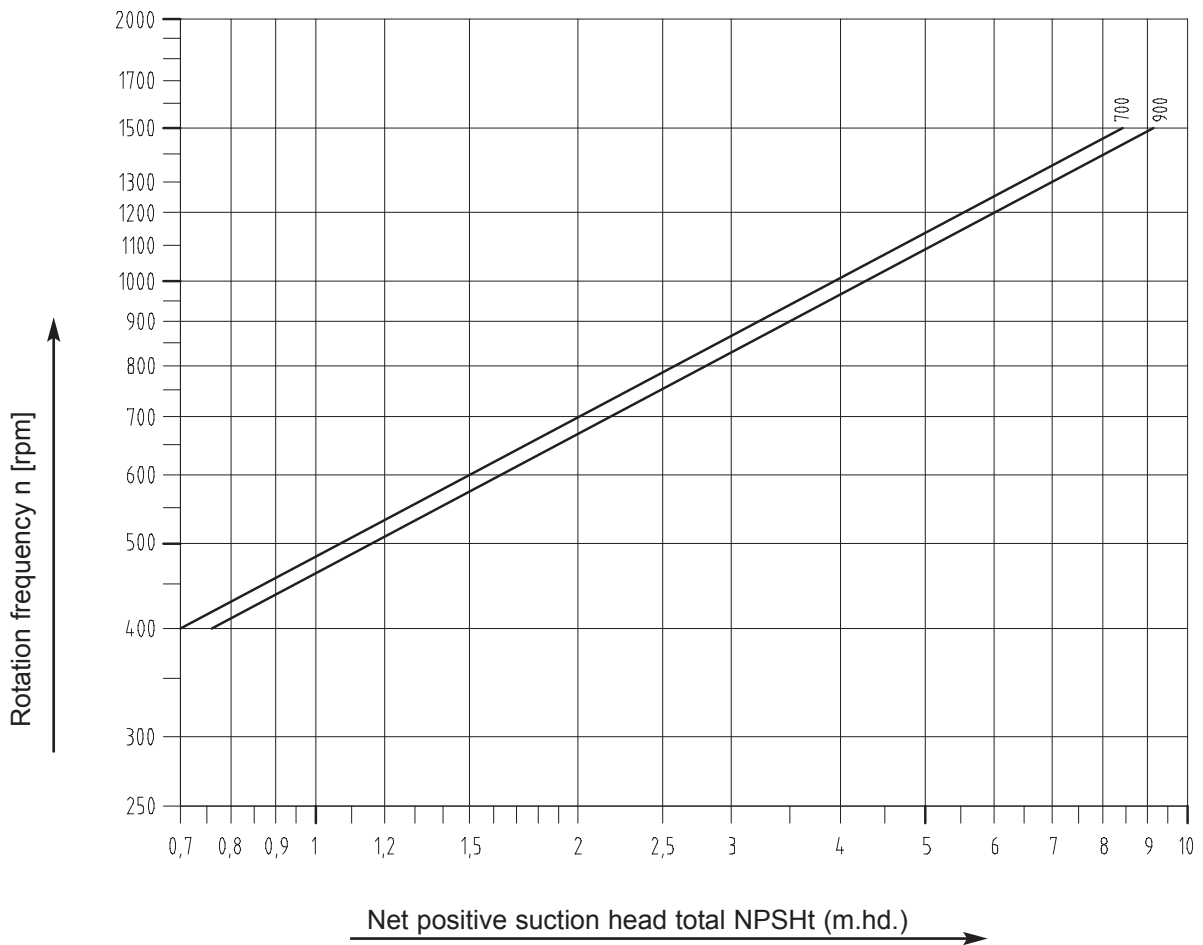

FPOD, FPOG, FPOJ, FPON, FPOS 80 - ...

Bypass valve control

Effect on rate of flow

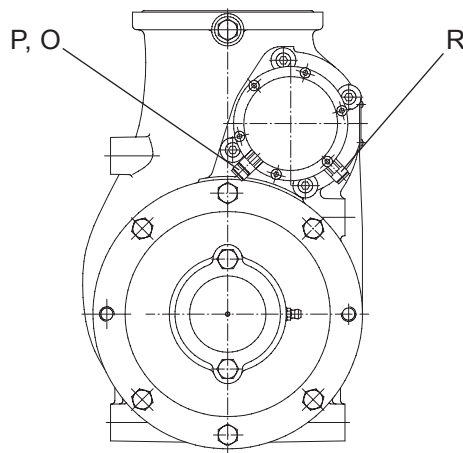

Attention: Do not remove the screws at the bypass valve cover. Risk of accident! Very strong pressure spring!

The bypass valve can release a connection internally between the pressure and the suction sides. It is held closed by means of a pressure-adjusting spring and, where applicable, additional pneumatic pressure (via "P") or pneumatically opened (via "O"). Depending upon the actuation the flow rate can be influenced as follows:

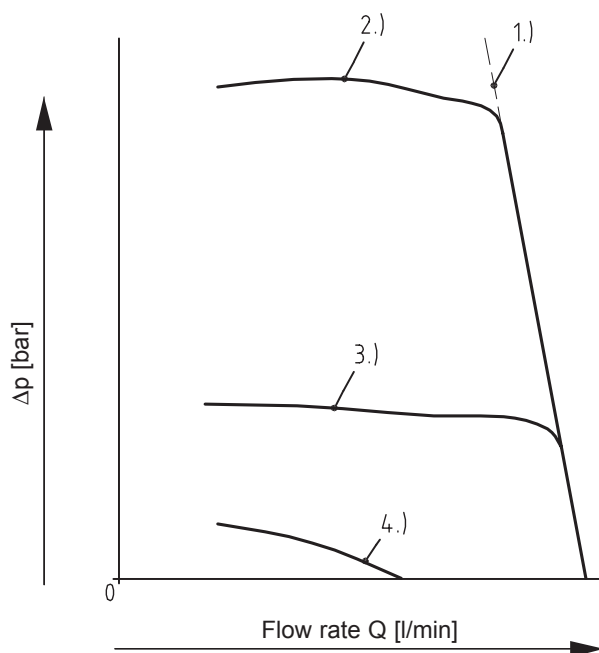

- 1.) Possible curve if no bypass valve present.
- 2.) Pressure-adjusting spring and pneumatic pressure to "P" (approx. 4.5 bar) provide the pumps max. Δp .
- 3.) Pneumatic pressure at "P" switched off e.g. through flow monitor. Only the pressure-adjusting spring exerts an influence.
- 4.) Pneumatic pressure at "P" switched off and at "O" min. 4 bar pneumatic pressure the bypass valve opens and it sets the Δp only relative to the pressure loss.

Flow control

A compressed air control can be applied for continuous adjustment of the rate of flow.

Installation

Preparation:

- Remove all transport packaging.
- Check pump for signs of any external transportation damage.

Installation position:

- Install pump stress-free in horizontal shaft bearing. Deviations of 5° to the horizontal are permissible.
- The pump can be installed upright, hanging or horizontally.
- In the event of horizontal installation the housing covers must be turned in the way that drainage bores are facing downwards.
- The housing cover opposite the drive should be accessible for service reasons.

Fastening:

- If required the pump can be flexibly suspended on silent bearings at its base fastening to dampen noise and vibrations. For this purpose a complete set consisting of 4 rubber-bonded metal suspension elements and the attendant threaded pins is available. **Part no. 1696676**

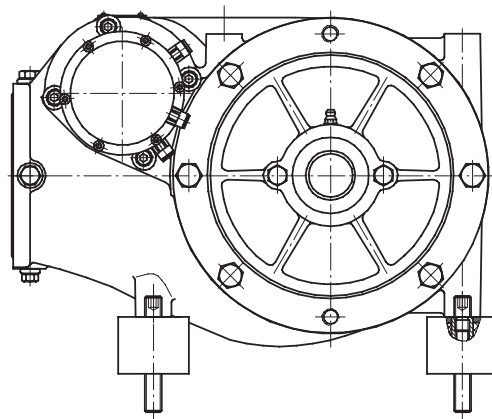

Weight of the set: 0.76 kg

FPOD, FPOG, FPOJ, FPON, FPOS 80 - ...

- For mounting in upright position the pump can be fixed with additional mounting angles (part no. 1133698).

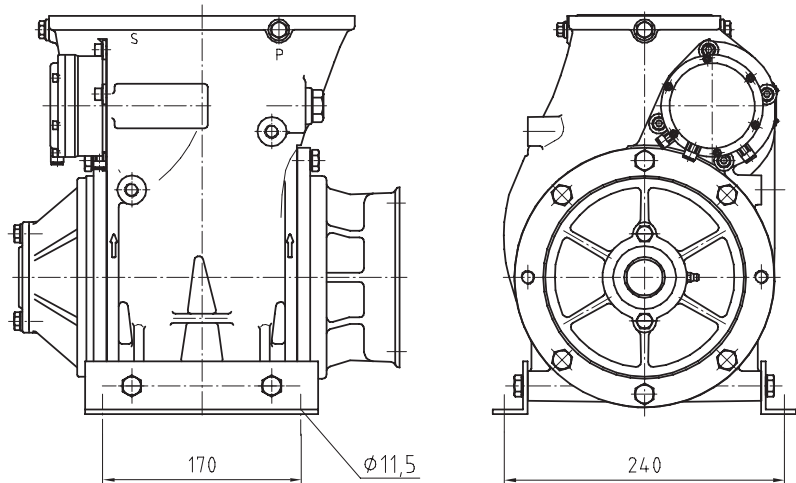

Assembly at inaccessible positions: Position pump lubricating points such that maintenance can be conducted without any risk.

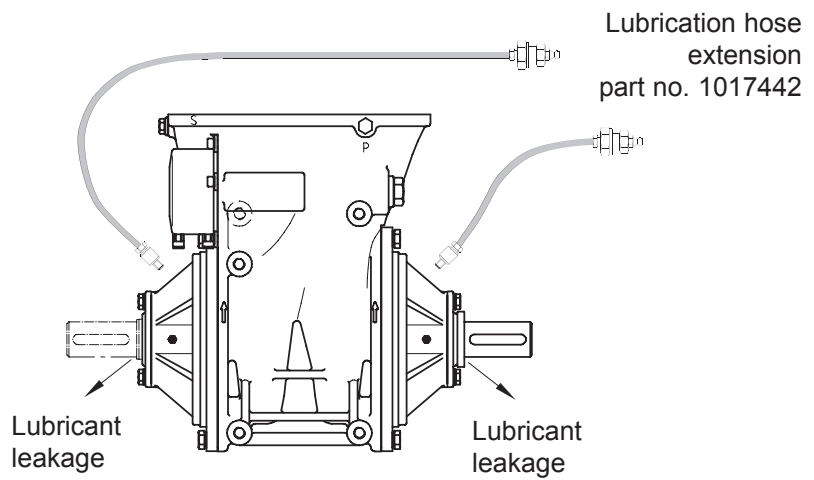

Pipeline connection: Pipelines can be connected using flexible connecting pipes. The pump is to have a filter fitted, mesh width $\leq 1000 \mu\text{m}$, on the suction side to protect it against mechanical damage caused by foreign bodies.

- Where possible the suction line should be short, straight and routed in a sufficient nominal width (to prevent cavitations).
- All pipelines are to be connected in accordance with the pump designations.
- For safety reasons the vane-type pump may only be operated with the overflow valve integrated into the system.

Accessory:

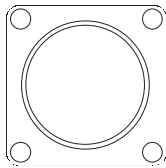

Square weld-on flange for suction line,
Material: Aluminium
Pipe connection DN 100
Screw connection DN 100
Part no.: 1147567



Square weld-on flange for discharge line,
Material: Aluminium
Pipe connection DN 80
Screw connection DN 100
Part no.: 1309974

Prop shaft drive: **During installation and maintenance of the propeller shaft, the manufacturer's specifications are to be adhered to!**

- Do not mount the propeller-shaft flange onto the pump shaft using hard impacts (use lubricant and plastic hammer).
- Use propeller shaft with linear compensation.
- The propeller shaft heads must be located on a single level (see Fig. 1). The propeller-shaft flange from the auxiliary drive and pump must be parallel (see Fig. 2).

FPOD, FPOG, FPOJ, FPON, FPOS 80 - ...

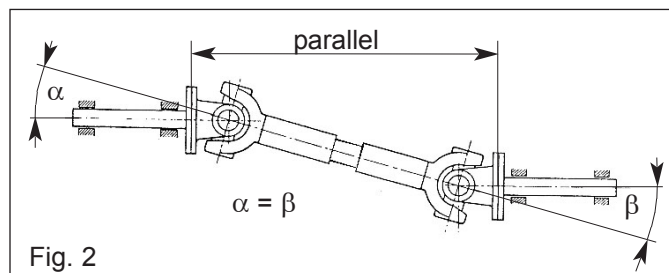
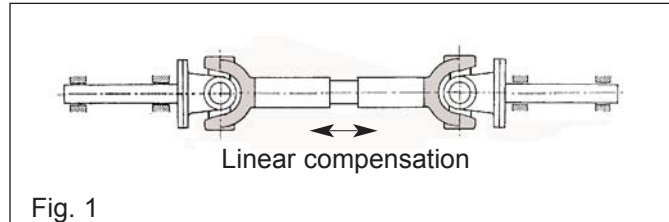

- A Z layout (see Fig. 2) should be strived for.
- Where possible angles α and β should be equal.
- If, depending on the speed, no other values have been specified by the propeller shaft manufacturer for bending angles (α or β), we would advise you not to exceed 10°
- The drive may not transmit any thrust to the pump drive shaft.
- If drive is provided by a vehicle engine then it must be ensured that the pump's drive is switched off when driving.

Accessories:

Prop shaft flange with projection for centring

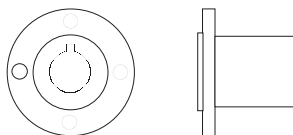

4 holes, outside diameter 90 mm
Bore $\varnothing 30 \times 50$ mm
Part no.: 1010677

Bore $\varnothing 30 \times 60$ mm
Part no.: 1013684

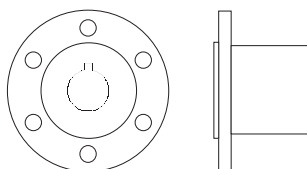

6 holes, outside diameter 100 mm
Bore $\varnothing 30 \times 50$ mm
Part no.: 1010685

Bore $\varnothing 30 \times 60$ mm
Part no.: 1013692

FPOD, FPOG, FPOJ,
FPON, FPOS 80 - ...



Prevention of
impermissible heating up:

Filled pump: Extended operation (> 5min) of the pump against the closed discharge side should be avoided due to impermissible build-up of heat.

Attention when dry running: - with the discharge closed, dry running must not exceed 1 minute
- with discharge open (\varnothing min. 6 mm) and without medium, dry running must not exceed 5 minutes.

Accessory:

Pneumatic temperature switch TPV 1A 3/2 + 1.3-70
Fastening screw thread: M12 x 18 long,
Switch-point: 70°C.
Part no. 2072303

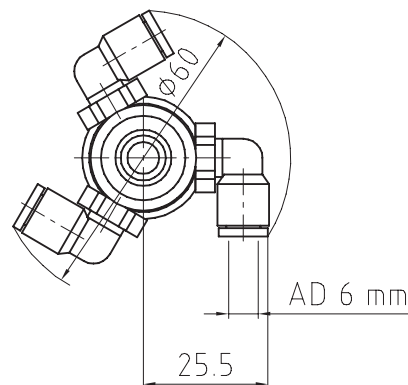
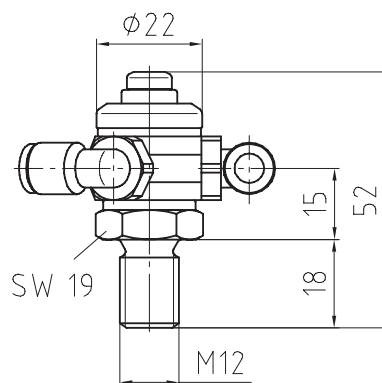

Schematic diagram

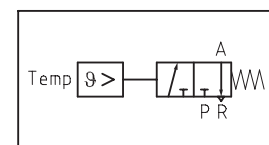

Weight: 0.083 kg

FPOD, FPOG, FPOJ, FPON, FPOS 80 - ...

Pressure monitoring: For adjustment and monitoring of the pump a manometer can be mounted on the pressure side.
A measurement point is available on the suction side.

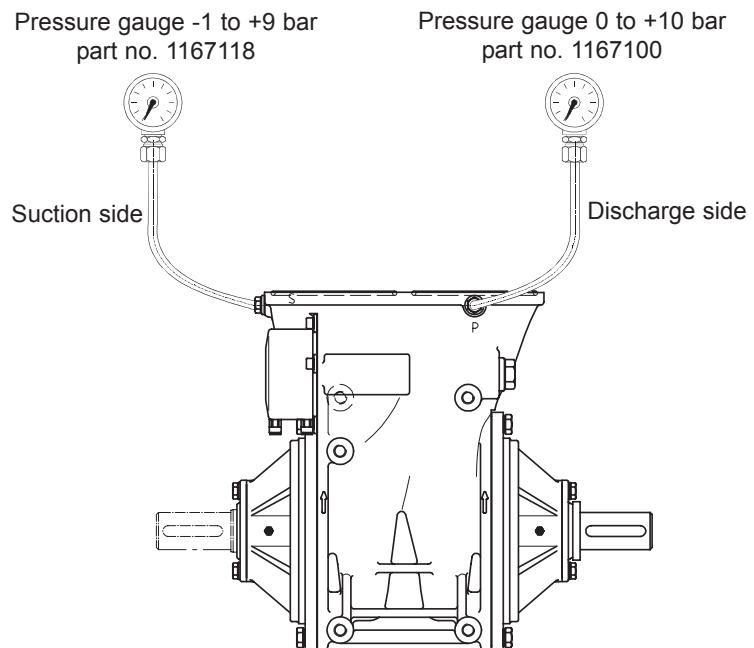

Speed adjustment at hydraulic drive: To set the speed, the shaft covering on the side opposite the drive can be removed.
This cover has to be mounted again after the measurement in order to avoid any bearing drift.

Start-up



If this is not observed people and material will be put at risk! Pump operation without any product will lead to an impermissible build up of heat (see note on page 17).

Checking direction of rotation: The drive's direction of rotation must match that of the pump.

initial start-up:

- Remove plugging for venting (connection "R").
- Check the installation in accordance with the operating instructions!
- Check the pipelines and all connections!
- Make sure that the pump speed does not exceed the maximum permissible speed.
- The bypass valve is to be relieved before switching on the pump. To this end, the applied air pressure should be reduced to zero and, once the pump has started, increased again.

Adjustment of pump pressure: The maximum pump pressure is set using the pneumatic pressure in the overflow valve.
To this end a manometer must be connected to the pump's pressure side. The manometer pressure is monitored to help gradually regulate the rate of delivery.
This can be done either by closing off the fuel nozzle or by making a bend in the delivery hose.

The air pressure on the overflow valve is gradually increased until the pressure-side manometer reaches the desired pump pressure.



In doing so the maximum pump pressure of 10 bar may not be exceeded.

FPOD, FPOG, FPOJ, FPON, FPOS 80 - ...

Maintenance

- Lubrication: The vane-type pump is to be lubricated at the bearing positions.
- Intervals: Every 600 operating hours or 3 years, whatever happens earlier.
- Lubricant: For standard operations: Beacon EP2 (part no. 1000189).
For low temperature operations (e.g. for type X1):
Molyduval Aero 14 (part no. 2067578).
- Procedure: Apply lubrication to the lubricating points during pump is running (without load, min. 300 rpm) until the grease is discharged at the exit points.
Danger - Be careful for running pumps!
- Central lubrication: This is permitted providing a suitable lubricant is used.

Troubleshooting

Fault:	Cause:	Remedy:
No pump suction / pump grows louder	Protective filter clogged	Clean filter
	Pump worn (high gap leakages)	Send pump to Service change vanes if necessary
Drive motor stops at pressure- side shutoff	Bypass valve setting too high	Check setting of bypass valve and set if necessary
Pump makes knocking noises and has reduced output	Delivery elements (vanes) broken	Send pump to Service
		Check pump's protective filter for signs of damage
Pump pressure too high	Bypass valve setting too high	Check setting of bypass valve and set if necessary
Pump pressure too low or not available	Bypass valve setting too low or faulty	Set bypass valve, replace if necessary
	Speed too low	Increase speed (n_{max})
No output	No venting	Remove plug for venting (connection "R")