



SELF SERVICE MC

FEATURES

- MULTI-USER MANAGEMENT
- WATER CAPTOR FILTER
- ALL-IN-ONE EQUIPMENT
- COMPACT DESIGN
- COMPATIBLE WITH SSM 2018 SOFTWARE
- IP55

The PIUSI SELF SERVICE MC is a complete device suitable to fit all diesel dispensing needs. With its sturdy structure, this dispenser is equipped with a high capacity vane pump, built-in bypass, automatic nozzle, water captor filter and electronic panel able to manage up to 80 users and 255 transactions.

PERFORMANCE

UP TO 90 L/MIN	AC
FLOW RATE	CONTINUOUS DUTY POWER
± 0,5%	UP TO 80
ACCURACY	USERS



ELECTRONIC METER INTEGRATED



SELF SERVICE MC

PACKAGING

CODE	WEIGHT		PACKAGING			N. BOXES / EUROPALLET	
	KG	LBS	MM	INCH	PCS/BOX	✕	

COLUMN VERSION

FO073801D	67	148	1478X488X400	-	1	6	4
FO074101D	75	165	1478X488X400	-	1	6	4
FO073806A	75	148	1478X488X400	-	1	6	4

TANK VERSION

FO0738B0D	57	126	1080X488X400	-	1	6	4
FO0741B0D	65	143	1080X488X400	-	1	6	4



FILTRATION



TANK MONITORING



HOSE REEL



ACCESSORIES



MERCHANDISE



AIR



ANTIFREEZE



AdBlue®



BIODIESEL



DIESEL



FOOD



GASOLINE



GREASE



KEROSENE



OIL



WATER



WINDSCREEN

CHART

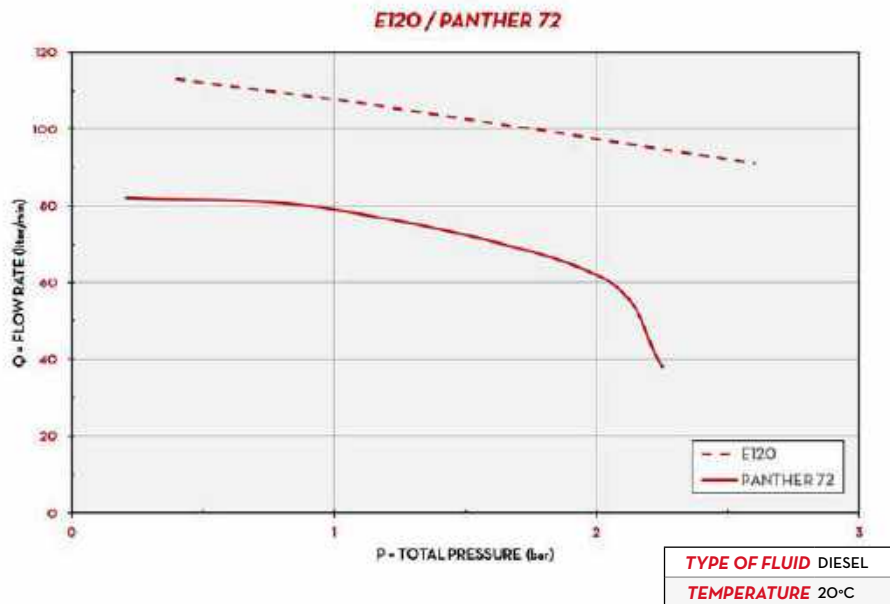

DIMENSIONS

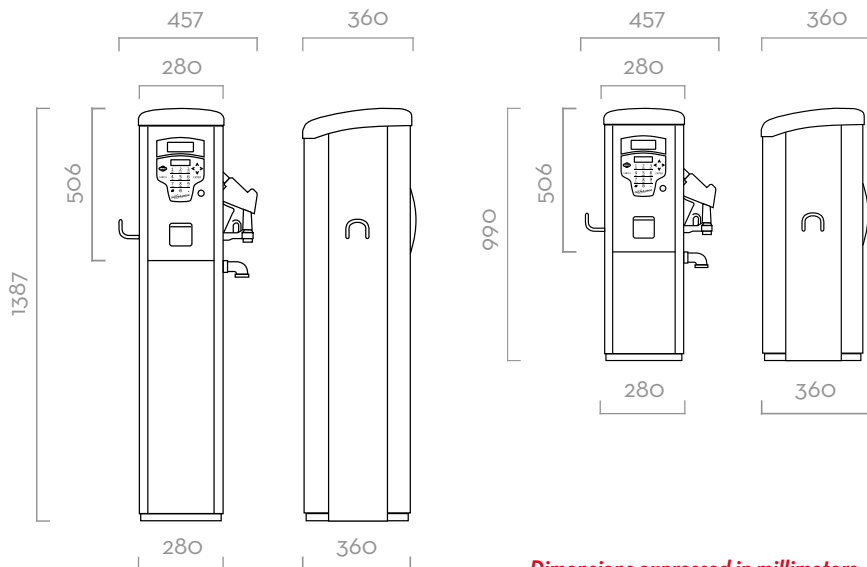

IN THE BOX

- SELF SERVICE MC DISPENSER
- DELIVERY HOSE
- AUTOMATIC NOZZLE
- INSTRUCTION MANUAL

DETAILS



TANK VERSION AVAILABLE



WATER CAPTOR FILTER (pag. 170)



DRIVER KEY (not included)



SSM 2018 SOFTWARE (pag. 42)

MATERIALS

- **PUMPS:**
PANTHER 72 / E120 PAG. 102/106
- **METER:**
K600/3 PAG. 134
- **NOZZLE:**
AUTOMATIC NOZZLE PAG. 158
- **FILTER:**
WATER CAPTOR PAG. 170

TECHNICAL DATA

CODE	DESCRIPTION	FLUIDS TYPE	FLOW RATE		VOLTAGE			PUMP TYPE	METER TYPE	NOZZLE TYPE	FILTER		INLET BSP	HOSE LENGTH METERS	PC CONNECTION
			L/MIN	GPM	AC V/ HZ DC VOLT	POWER WATT	AMP. MAX.				H2O FILTER	FILTERING CAPACITY			

COLUMN VERSIONS

FO073801D	SELF SERVICE 70 MC F	D	70	18	230/50	900	4,2	PANTH 72	K600	A80	YES	30µ	1" 1/2	4	YES
FO074101D	SELF SERVICE 100 MC F	D	90	24	230/50	1150	5,7	E 120	K600	A120	YES	30µ	1" 1/2	4	YES
FO073806A	SELF SERVICE 70 MC F PRINTER	D	70	18	230/50	900	4,2	PANTH 72	K600	A80	YES	30µ	1" 1/2	4	YES

TANK VERSIONS

FO0738B0D	SELF SERVICE 70 MC TANK	D	70	18	230/50	900	3,3	PANTH 72	K600	A80	NO	-	1" 1/2	4	YES
FO0741B0D	SELF SERVICE 100 MC TANK	D	90	24	230/50	1150	5,7	E 120	K600	A120	NO	-	1" 1/2	4	YES

WITH 7M HOSE. UPON REQUEST IT IS AVAILABLE WITH DIFFERENT VOLTAGES AND 60 HZ FREQUENCY

SELF SERVICE MC