



FUEL MANAGEMENT SYSTEMS



DISPENSERS



KITS



PUMPS



METERS



NOZZLES

ST 200 AC

FEATURES

- STURDY METALLIC FRAME
- READY TO USE
- EASY TO MOVE
- HEAVY DUTY

The PIUSI ST 200 AC is a dispenser that allows high flow refueling thanks to the two integrated E120 self-priming rotary electric vane pumps. Fitted with by-pass valve and elevated reliability seal, the dispenser works even at low working temperatures and in every condition on worksites. The oval gear mechanical flow meter guarantees great precision (available on request). It is also available with wheels and handle (on request) for easier handling.

PERFORMANCE

UP TO
200 L/MIN

FLOW RATE

AC
CONTINUOUS DUTY

POWER



ST 200 AC



HANDY KIT: VERSION WITH WHEELS AND HANDLE

PACKAGING

CODE	WEIGHT		PACKAGING		
	KG	LBS	MM	INCH	PCS/BOX
FO0315000	46	101	587X395X420	23,1X15,6X16,5	1
F16860000	-	-	-	-	-



FILTRATION



TANK MONITORING



HOSE REEL



ACCESSORIES



MERCHANDISE



AIR



ANTIFREEZE



AdBlue®



BIODIESEL



DIESEL



FOOD



GASOLINE



GREASE



KEROSENE



OIL



WATER



WINDSCREEN

CHART

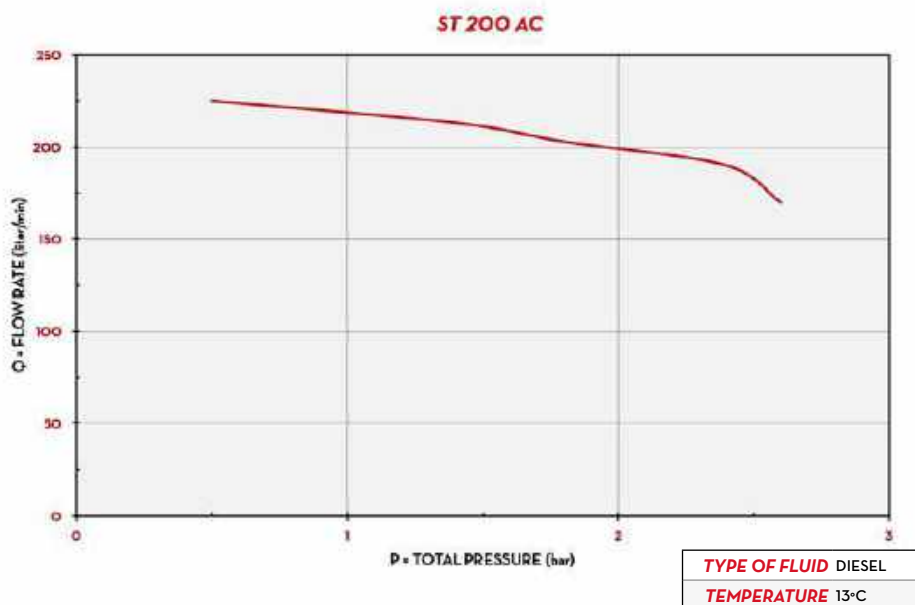

IN THE BOX

- ST 200 AC UNIT
- INSTRUCTION MANUAL

DETAILS



DIMENSIONS

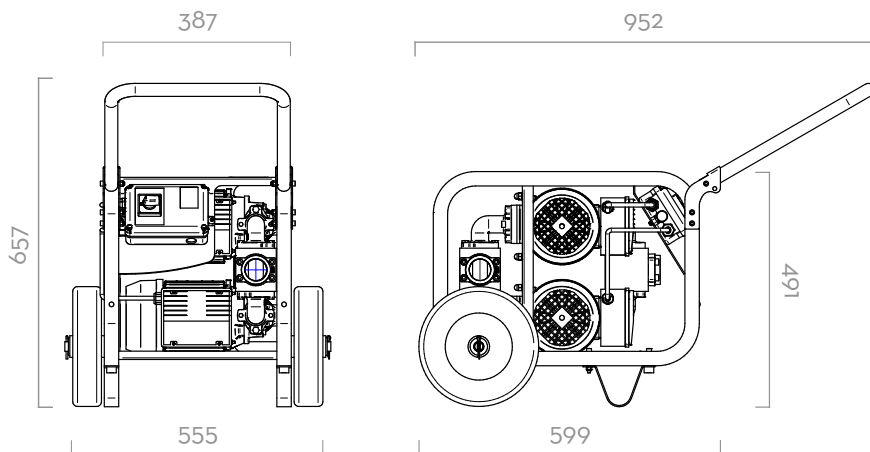

MATERIALS

- BODY: CAST IRON
- ROTOR: SINTERED STEEL
- VANES: ACETAL RESIN
- SEAL: VITON
- SHAFT: STEEL

Dimensions expressed in millimeters

TECHNICAL DATA

CODE	DESCRIPTION	FLUIDS TYPE	FLOW RATE		VOLTAGE			PUMP		MAX PRESSURE	OUTLET	
			L/MIN	GPM	AC V/HZ	DC VOLT	POWER WATT	AMP. MAX.	TYPE	N°	BAR	BSP
FO0315000	ST 200 BASIC	D	200	52,7	230/50	-	2050	10	E 120	2	2,5	1" 1/2
F16860000	HANDY KIT (HANDLE + WHEELS)	D	-	-	-	-	-	-	-	-	-	-