



CAR FILLING



DISPENSERS



PUMPS



METERS



NOZZLE METERS



NOZZLES

MP 140

FEATURES

- IN/OUT INTERCHANGEABLE
- BUILT-IN DIFFUSER
- SUITABLE FOR SUBMERSIBLE INSTALLATION
- HEAVY DUTY
- EASY TO FIT
- STURDY DESIGN

The Piusi MP 140 is a long-lasting (o life-long) pneumatic diaphragm pump suitable for transferring AdBlue®. The small size of this pump allows a wide range of installations , even in severe duty conditions.



PERFORMANCE

UP TO

100 L/MIN

FLOW RATE

MAX CAPACITY

6M

SELF PRIMING

MAX

7 BAR

AIR SUPPLY

PRESSURE

MAX

Ø 4MM

PASSING SOLID



MP140

PACKAGING

CODE	WEIGHT		PACKAGING		
	KG	LBS	MM	INCH	PCS/BOX
FOO208P20	5	11	240X380X350	9,4X15X13,8	1



FILTRATION



FLUID MONITORING



HOSE REELS



ACCESSORIES



MERCHANDISE



AIR



ANTIFREEZE



AdBlue®



BIODIESEL



DIESEL



FOOD



GASOLINE



GREASE



KEROSENE



OIL



WATER



WINDSCREEN

CHARTS

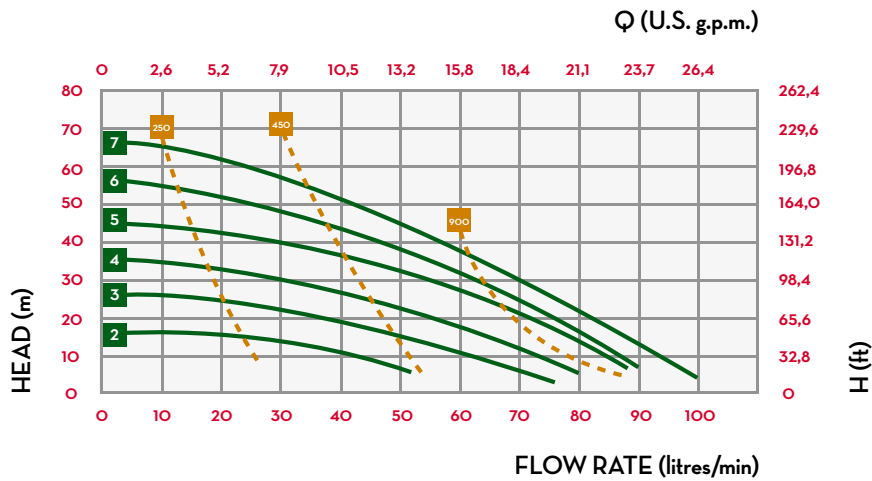

IN THE BOX

- MP PUMP
- INSTRUCTION MANUAL

DETAILS



HEAVY DUTY MATERIALS



TECHNOPOLYMER BODY



STURDY DESIGN

DIMENSIONS

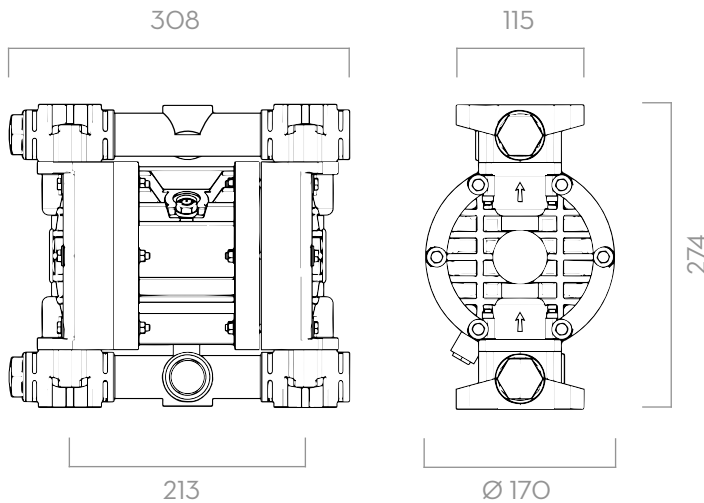

Dimensions expressed in millimeters

MATERIALS

- BODY: TECHNOPOLYMER
- SIDE PARTS AND COLLECTORS: POLYPROPYLENE
- DIAPHRAGM: EPDM

TECHNICAL DATA

CODE	DESCRIPTION	FLUIDS TYPE	PUMP BODY	IN / OUT	FLOW RATE L/MIN	MEMBRANE TYPE	DIAPHRAGM AIR SIDE/ FLUID SIDE	BALLS	BALL SEATS*	O-RING*	INTAKE / DELIVERY CONNECTION	AIR CONNECTION	MAX SELF-PRIMING CAPACITY	MAX HEAD**	MAX AIR SUPPLY PRESSURE	MAX Ø OF PASSING SOLID
													M	M	BAR	MM
FOO208P20	PIUSI MP 140		POLYPROPYLENE	1" G	100	DOUBLE	PTFE/ HYTREL	PTFE	POLYPROPYLENE	PTFE	G 1" F	G 3/8" F	6	70	7	4

(*) ON REQUEST WE CAN PROVIDE MEMBRANES, BALLS, BALL SEATS AND O-RINGS IN DIFFERENT MATERIALS.

(**) THE VALUE DEPENDS ON THE CONFIGURATION OF THE PUMP