

Energy products

Maintenance Manual

Underwing Refuelling Nozzle

F116 Series

MMF116
Revision 2.0
01 August 2013



Meggitt (North Hollywood), Inc. Proprietary Information

The information contained in this document is disclosed in confidence. It is the property of Meggitt (North Hollywood), Inc. and shall not be used, disclosed to others, or reproduced in whole or in part without the express written consent of Meggitt (North Hollywood), Inc. If consent is given, this notice shall appear in any such reproduction. These commodities, technology, or software were exported from the United States in accordance with the export administration regulations. Diversion contrary to U.S. law is prohibited.

SENSITIVE BUT UNCLASSIFIED-EXPORT CONTROLLED-EAR RESTRICTED.

These commodities, technology or software are exported from the United States of America in accordance with the Export Administration Regulations. ECCN EAR99. Diversion contrary to U.S. law is prohibited.

Copyright © 2013 Meggitt (North Hollywood), Inc.

Meggitt Control Systems

Our product competencies & services:
Aerospace valves | Thermal management solutions | Environmental control systems | Electro-mechanical products
Ground fuelling products | Energy products | Aftermarket services

MEGGITT
smart engineering for
extreme environments



Energy products

Meggitt Fuelling Products
Maintenance Manual
Underwing Refuelling Nozzle – F116 Series

REVISION RECORD

Keep this record in the front of the manual. When you get the revisions, put the revised pages in the manual. Write the revision number, date issued and your initials on this page.

Rev No.	PAGES AFFECTED	DESCRIPTION OF CHANGE	DATE	APPROVED BY
1.0	ALL	Initial Release	11/01/2001	
1.1	ALL	-	02/15/2002	
1.2	ALL	-	07/15/2003	
1.3	ALL	-	10/01/2004	
1.4	ALL	-	03/15/2005	
1.5	ALL	-	02/01/2006	
2.0	ALL	See DCN	08/01/2013	

USE OR DISCLOSURE OF DATA ON THIS PAGE IS SUBJECT TO THE RESTRICTIONS ON THE TITLE PAGE OF THIS DOCUMENT

 Energy productsMeggitt Fuelling Products
Maintenance Manual
Underwing Refuelling Nozzle – F116 Series**TABLE OF CONTENTS**

<u>SUBJECT</u>	<u>PAGE</u>
IMPORTANT SAFETY INSTRUCTIONS.....	1
INTRODUCTION.....	3
DESCRIPTION AND OPERATION	4
SPECIAL TOOLS AND TEST EQUIPMENT	10
TESTING	11
FAULT ISOLATION.....	13
REPAIR TASKS	16
CLEANING.....	23
CHECK/INSPECTION.....	25
ILLUSTRATED PARTS LIST.....	30

LIST OF ILLUSTRATIONS

<u>FIGURE</u>	<u>PAGE</u>
Figure 1. Underwing Fuelling Nozzle	5
Figure 2. Connector Wear Limits (Sheet 1 of 2).....	28

LIST OF TABLES

<u>TABLE</u>	<u>PAGE</u>
Table 1 Leading Particulars.....	6
Table 2 Nozzle Variations (Mod Code Group After F116).....	7
Table 3 Coupling Variations (Type Number between the Mod and Type Letter Groups).....	8
Table 4 Swivel Body Inlet Variations (End Type Letter)	8
Table 5 F116 Series Replacements for Earlier Series Nozzles.....	9
Table 6 Special Tools and Test Equipment	10
Table 7 Fault Isolation	13
Table 8 Recommended Cleaning Materials.....	23
Table 9 Component Checks	25

USE OR DISCLOSURE OF DATA ON THIS PAGE IS SUBJECT TO THE RESTRICTIONS ON THE TITLE PAGE OF THIS DOCUMENT

01 Aug 2013

Revision 2.0

i

Meggitt Control Systems

Our product competencies & services:
 Aerospace valves | Thermal management solutions | Environmental control systems | Electro-mechanical products
 Ground fuelling products | Energy products | Aftermarket services

MEGGITT
 smart engineering for
 extreme environments

Energy products

Meggitt Fuelling Products Maintenance Manual Underwing Refuelling Nozzle – F116 Series

IMPORTANT SAFETY INSTRUCTIONS

SAVE THESE INSTRUCTIONS!

This manual contains important instructions that should be followed during installation and maintenance of the Underwing Refuelling Nozzle. The following are general safety precautions that are not related to specific procedures and therefore do not appear elsewhere in this publication. These are recommended precautions that personnel must understand and apply during maintenance.

The nozzle is a mechanical device and can be dangerous if not correctly operated or maintained.

Safety Alert Symbols

Safety alert symbols are used in this manual to identify potential or immediate personal injury hazards. The safety alert symbol words are explained below:



- indicates an imminently hazardous situation which, if not avoided, will result in injury or serious injury.



- indicates a potentially hazardous situation which, if not avoided, could result in injury or serious injury.



- indicates a potentially hazardous situation which, if not avoided, may result in minor or moderate injury.



- used without the safety alert symbol indicates a potentially hazardous situation which, if not avoided, may result in property damage.

WEAR PROTECTIVE CLOTHING

- Wear protective clothing (gloves, apron, etc.) approved for the materials and tools being used.

USE APPROVED SAFETY EQUIPMENT

- Use only approved equipment and make sure firefighting equipment is readily available.

USE OR DISCLOSURE OF DATA ON THIS PAGE IS SUBJECT TO THE RESTRICTIONS ON THE TITLE PAGE OF THIS DOCUMENT

01 Aug 2013

Revision 2.0

1

Meggitt Control Systems

Our product competencies & services:
Aerospace valves | Thermal management solutions | Environmental control systems | Electro-mechanical products
Ground fuelling products | Energy products | Aftermarket services

MEGGITT
smart engineering for
extreme environments

Energy products

Meggitt Fuelling Products Maintenance Manual Underwing Refuelling Nozzle – F116 Series

GIVE CLEANERS SPECIAL CARE

- When cleaners are being used read and follow the material safety data sheet (MSDS) instructions for correct handling.

Equipment Safety Information

The following safety information briefly discusses hazards peculiar to the equipment, which are likely to be encountered during maintenance activity.

GENERAL OPERATING LOCATION PRECAUTIONS

- Use only authorized replacement parts or hardware.
- Obey Lock-Out/Tag-Out procedures when working on the nozzle and make sure personnel protection equipment such as electrical grounds are installed.

OPERATION AND MAINTENANCE OF FUEL SYSTEMS

- Protect all fuel lines from damage or puncture. Do not operate the nozzle if a fuel leak is detected.
- Do not use flammable solvents for cleaning parts.
- Check for tools, rags, or loose parts left in the area before resuming operation.
- Do not attempt to remove the nozzle from the system without first isolating it from the line pressure and venting all of the trapped internal pressure.

USE OR DISCLOSURE OF DATA ON THIS PAGE IS SUBJECT TO THE RESTRICTIONS ON THE TITLE PAGE OF THIS DOCUMENT

01 Aug 2013

Revision 2.0

2

Meggitt Control Systems

Our product competencies & services:
Aerospace valves | Thermal management solutions | Environmental control systems | Electro-mechanical products
Ground fuelling products | Energy products | Aftermarket services

MEGGITT
smart engineering for
extreme environments



Energy products

Meggitt Fuelling Products Maintenance Manual Underwing Refuelling Nozzle – F116 Series

INTRODUCTION

1. General

The information and procedures contained in this manual have been prepared to assist qualified repair personnel in off-aircraft maintenance of the Underwing Refuelling Nozzle. The instructions provide information necessary to perform maintenance functions. The nozzle is manufactured by Meggitt (North Hollywood), Inc., 12838 Saticoy Street, North Hollywood, California 91605.

2. Scope

The instructions contained in this manual do not claim to cover all details or variations in equipment. They do not provide for every problem that could occur during installation, operation, or maintenance. If further information is required, contact Meggitt (North Hollywood), Inc., Product Support Department.

3. Standard Shop Practices

Use approved procedures and safety precautions to prevent damage to the equipment and injury to personnel.

4. Weights and Measurements

Weights and measurements in this manual are expressed in both English (U.S. customary) and Metric (SI) units.

5. Revision Service

This manual will be revised, as necessary, to reflect current information.

USE OR DISCLOSURE OF DATA ON THIS PAGE IS SUBJECT TO THE RESTRICTIONS ON THE TITLE PAGE OF THIS DOCUMENT

01 Aug 2013

Revision 2.0

3

Meggitt Control Systems

Our product competencies & services:
Aerospace valves | Thermal management solutions | Environmental control systems | Electro-mechanical products
Ground fuelling products | Energy products | Aftermarket services

MEGGITT
smart engineering for
extreme environments

Meggitt Fuelling Products
Maintenance Manual
Underwing Refuelling Nozzle – F116 Series

DESCRIPTION AND OPERATION

1. Description

The Underwing Refueling Nozzle (nozzle) (See [Figure 1](#)) provides the means of controlling the flow of fuel in pressure fueling operations. The nozzle inlet port couples to a fueling hose. The outlet port attaches to the inlet adapter of the system being fueled. The nozzle provides a leak-proof connection between the system being fueled and the fuel supply.

2. Operation

A. Uncoupled

When the nozzle is not coupled to a mating fuel system inlet adapter, its poppet valve is closed, so that there is no flow or leakage of fuel from the outlet port. The flow control handle that operates the poppet valve remains locked in the CLOSED position until the nozzle is coupled to the mating fuel system inlet adapter.

B. Coupling and Opening

When the nozzle is coupled to the mating fuel system inlet adapter, the nose seal of the nozzle is compressed against the sealing surface of the inlet adapter to form a fluid-tight connection. When the nozzle is fully engaged and locked to the bayonet flange of the inlet adapter, the flow control handle is unlocked. Rotation of the flow control handle to the OPEN position opens the poppet valve, providing a flow passage into the system being fueled. As the system is being fueled, fuel pressure acts on the floating nose seal of the nozzle to increase the sealing force.

C. Closing and Uncoupling

Rotation of the flow control handle to the CLOSED position closes the poppet valve and the flow passage into the system being fueled. When the nozzle is unlocked and disengaged from the bayonet flange of the inlet adapter, the flow control handle is locked in the CLOSED position.

D. Adapters

Suitable attachment adapters such as swivels and/or hose end control valves (HECV) may be used to adapt the nozzle to any fuel system.

USE OR DISCLOSURE OF DATA ON THIS PAGE IS SUBJECT TO THE RESTRICTIONS ON THE TITLE PAGE OF THIS DOCUMENT

Energy products

Meggitt Fuelling Products Maintenance Manual Underwing Refuelling Nozzle – F116 Series

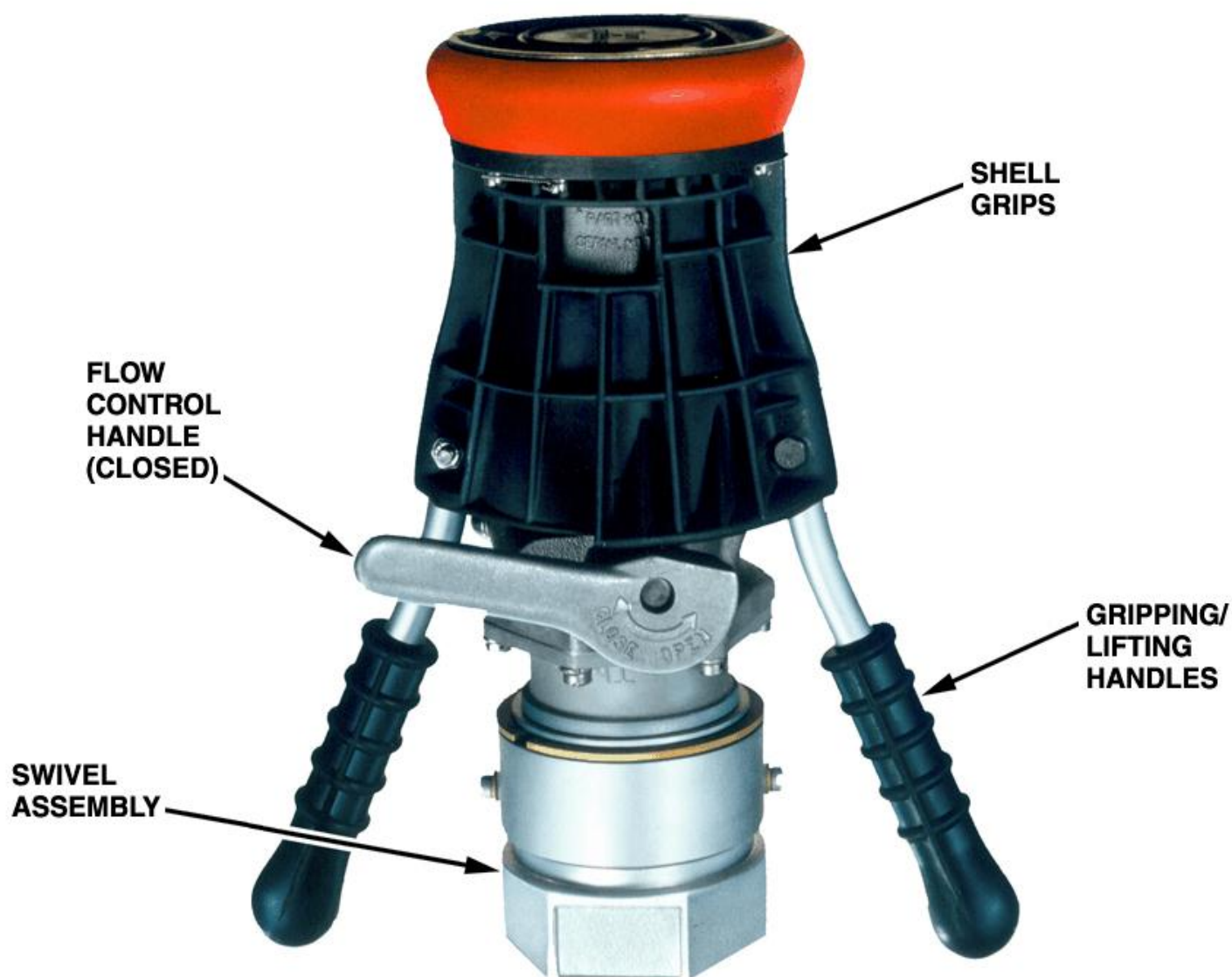

Figure 1. Underwing Fuelling Nozzle

USE OR DISCLOSURE OF DATA ON THIS PAGE IS SUBJECT TO THE RESTRICTIONS ON THE TITLE PAGE OF THIS DOCUMENT

01 Aug 2013

Revision 2.0

5

Meggitt Control Systems

Our product competencies & services:
Aerospace valves | Thermal management solutions | Environmental control systems | Electro-mechanical products
Ground fuelling products | Energy products | Aftermarket services

MEGGITT
smart engineering for
extreme environments

Energy products

Meggitt Fuelling Products Maintenance Manual Underwing Refuelling Nozzle – F116 Series

3. Leading Particulars

For the leading particulars refer to [Table 1](#).

Table 1 Leading Particulars

Service	Automotive and Aviation Fuels
Operating Pressure (maximum)	120 psig (827.3 kPaG)
Fluid Temperature	–40 to 165°F (–40 to 74°C)
Ambient Temperature	–40 to 165°F (–40 to 74°C)
Mating Inlet Flanges	F574/F594/F595 HECV, F575/F584, F577/F582 F581 Swivels, F596 Dry Disconnect

4. Model Variations

The basic F116 series nozzle is a straight-in fueling nozzle with a flanged inlet designed to mate with various swivel types. It is equipped with replaceable bicycle grip handles and a dust cover. A swivel is not supplied with the basic nozzle, but can be ordered as a variation. Refer to Tables 2, 3 and 4 for the available F116 series nozzle variations. Many variations are available. An explanation of the F116 series part numbering system is shown below:

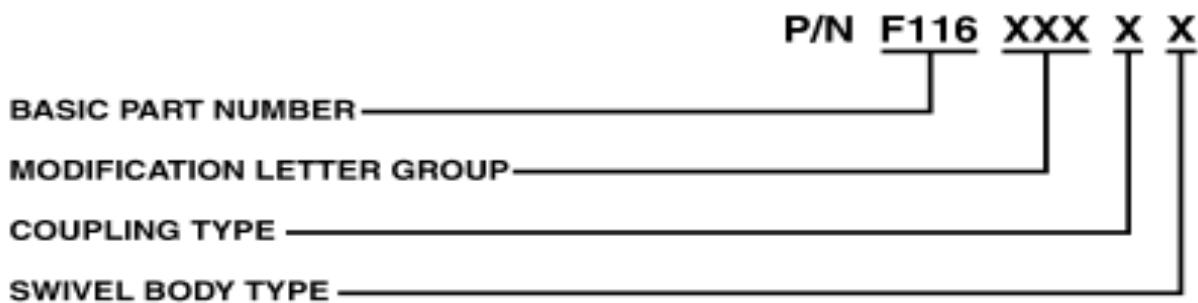

P/N Example: F116BCHM3A – This nozzle is equipped with a vacuum breaker, has stirrup handles, 35 PSI HECV and 0-100 PSI Pressure gage without strainer. The coupling is the 3-inch aluminum type with wire raceways to mate with the F575/F584 swivel body. The swivel body has a 2 ½ inch NPT inlet.

USE OR DISCLOSURE OF DATA ON THIS PAGE IS SUBJECT TO THE RESTRICTIONS ON THE TITLE PAGE OF THIS DOCUMENT

Energy products

Meggitt Fuelling Products Maintenance Manual Underwing Refuelling Nozzle – F116 Series

Table 2 Nozzle Variations (Mod Code Group After F116)

Examples: F116A2A, F116BCHM2A

NOZZLE MOD LETTER	DESCRIPTION
A	Adds grounding cable
B	Adds vacuum breaker
C	Replaces bicycle handles with stirrup handles
D	Replaces standard length handles with 10-inch long handles
F	Adds 2½-inch ANPT female threaded inlet
G	Adds 45 PSI (310 kPa) HECV
H	Adds 35 PSI (241 kPa) HECV
J	Replaces standard connector with replaceable wear points
K	Adds adapter for J. C. Carter inlet flange
L	Adds 50 PSI (345 kPa) HECV
M	Adds 0 to 100 PSIG pressure gage
N	Replaces standard nose seal with flexible nose seal
P	Adds 55 PSI (379 kPa) HECV
Q	Adds 45° adapter for MS33786-40 2½-inch inside diameter flange
R	Adds grounding cable, 100 mesh strainer and 2½-inch (63.5 mm) coupling with 2-inch (50.8 mm) female cam lock inlet
S	Adds grounding cable, 100 mesh strainer, and 2½-inch (63.5 mm) coupling with 4-inch (101.6 mm) female cam lock inlet
T	Adds 40-mesh strainer suitable for the coupling type
U	Adds 60-mesh strainer suitable for the coupling type
V	Adds 100-mesh strainer suitable for the coupling type
W	Adds adapter for MS33786-40 (2½-inch) inside diameter flange
X	Replaces standard body with heavy duty type with replaceable nose
Z	Adds 6-slot connector

USE OR DISCLOSURE OF DATA ON THIS PAGE IS SUBJECT TO THE RESTRICTIONS ON THE TITLE PAGE OF THIS DOCUMENT

01 Aug 2013

Revision 2.0

7

Meggitt Control Systems

Our product competencies & services:
Aerospace valves | Thermal management solutions | Environmental control systems | Electro-mechanical products
Ground fuelling products | Energy products | Aftermarket services

MEGGITT
smart engineering for
extreme environments

Energy products

Meggitt Fuelling Products Maintenance Manual Underwing Refuelling Nozzle – F116 Series

Table 3 Coupling Variations (Type Number between the Mod and Type Letter Groups)

Examples: F116A2A, F116BCHM6A

COUPLING TYPE NUMBER	DESCRIPTION
2	Bronze coupling (2½-inch) to mate with F501, F577, F582 swivel body (uses 2½-inch strainer). (When replacing strainer, use F582E7)
3	Standard 3-inch aluminum coupling with corrosion resistant steel wire races to mate with F575/F584 swivel body (uses 3-inch strainer)
4	Standard 3 inch aluminum coupling with corrosion resistant steel wire races to mate with F596 dry disconnect swivel assembly (uses 3-inch strainer)
5	Bronze coupling to mate with flight refueling swivel body
6	Standard 2½ inch aluminum coupling with corrosion resistant steel wire races to mate with F1516 dry disconnect swivel assembly (uses 2½-inch strainer)
7	Standard 2½-inch aluminum coupling with corrosion resistant steel wire races to mate with F577/F582 swivel body (uses 2½-inch strainer)

Table 4 Swivel Body Inlet Variations (End Type Letter)

Examples: F116A4A, F116BCHM7E

SWIVEL BODY TYPE LETTER	DESCRIPTION
A	2½-inch ANPT inlet. Available for coupling types 3, 4, 6 or 7 only.
B	2½-inch BSPPL inlet. Available for coupling types 3, 4, 6 or 7 only.
C	3-inch ANPT inlet. Available for coupling types 3, 4, 6 or 7 only.
D	2-inch ANPT inlet. Available for coupling types 3, 4, 6 or 7 only.
E	3-inch BSPPL inlet. Available for coupling types 3, 4, 6 or 7 only.
F	2-inch BSPPL inlet. Available for coupling type 6 only. (Early production type 3, 4 or 7 nozzles: 3-inch National Valve type end connection.)
G	3-inch BSPPL inlet. Available for coupling type 7 only.
K	4-inch ANPT inlet. Available for coupling type 7 only.

USE OR DISCLOSURE OF DATA ON THIS PAGE IS SUBJECT TO THE RESTRICTIONS ON THE TITLE PAGE OF THIS DOCUMENT

Energy products

Meggitt Fuelling Products Maintenance Manual Underwing Refuelling Nozzle – F116 Series

Table 4 Swivel Body Inlet Variations (End Type Letter) - (Cont.)

Examples: F116A4A, F116BCHM7E

SWIVEL BODY TYPE LETTER	DESCRIPTION
T	2-inch female Camlock inlet. Available for coupling type 7 only.
U	4-inch female Camlock inlet. Available for coupling type 7 only.
V	3½-inch ANPT inlet. Available for coupling type 7 only.
X	2-inch BSPPL inlet. Available for coupling type 7 only.

5. Model Equivalents

Table 5 is a matrix showing substitution equivalency of earlier F100/F110/F115 series nozzles with current production F116 series replacement nozzles.

Table 5 F116 Series Replacements for Earlier Series Nozzles

F100/F110/F115 NOZZLE PART NUMBERS	F116 REPLACEMENT NOZZLE PART NUMBERS
F100/F110/F115T2A	F116T7A (2½-inch diameter coupling and strainer)
F100ABDN/F110ABDN/F115ABV3D	F116ABV7D (2½-inch diameter coupling and strainer)
F100D/F110D/F115T2D	F116T7D (2½-inch diameter coupling and strainer)
F100DN/F110DN/F115V2D	F116V7D (2½-inch diameter coupling and strainer)
F100N/F110N/F115V2A	F116V7A (2½-inch diameter coupling and strainer)
F115ABV3D	F116ABV3D* (3-inch diameter coupling and strainer)
F115T3A	F116T3A* (3-inch diameter coupling and strainer)
F115T3D	F116T3D* (3-inch diameter coupling and strainer)
F115V3A	F116V3A* (3-inch diameter coupling and strainer)
F115V3D	F116V3D* (3-inch diameter coupling and strainer)

*Indicates functionally equivalent F116 series nozzles that are not completely interchangeable with the earlier models, since they differ in the disconnect area, having 3-inch diameter couplings and strainers.

USE OR DISCLOSURE OF DATA ON THIS PAGE IS SUBJECT TO THE RESTRICTIONS ON THE TITLE PAGE OF THIS DOCUMENT

Energy products

Meggitt Fuelling Products Maintenance Manual Underwing Refuelling Nozzle – F116 Series

SPECIAL TOOLS AND TEST EQUIPMENT

1. General

Special tools and test equipment recommended for maintenance of the nozzle are listed in [Table 6](#)

Table 6 Special Tools and Test Equipment

PART NUMBER	DESCRIPTION	APPLICATION
C1-0-486	Hand Reamer	Alignment of the handle shaft bearings
F65-0-1130	Nose Seal Test Fixture	Leakage testing of the nose seal
2706112-102	Gage Assembly	Adjustment of the nose seal
GTP-8963	Gage, Adapter Wear	Checking adapter wear
2872018	Test Plug, 3-inch ANPT	Leakage testing of 3-inch NPT connections
2872019	Test Plug, 3-inch BSPPL	Leakage testing of 3-inch BSPPL connections
2872020	Test Plug, 2½-inch ANPT	Leakage testing of 2½-inch NPT connections
2872021	Test Plug, 2½-inch BSPPL	Leakage testing of 2½-inch BSPPL connections

USE OR DISCLOSURE OF DATA ON THIS PAGE IS SUBJECT TO THE RESTRICTIONS ON THE TITLE PAGE OF THIS DOCUMENT

01 Aug 2013

Revision 2.0

10

Meggitt Control Systems

Our product competencies & services:
Aerospace valves | Thermal management solutions | Environmental control systems | Electro-mechanical products
Ground fuelling products | Energy products | Aftermarket services

MEGGITT
smart engineering for
extreme environments



Energy products

Meggitt Fuelling Products Maintenance Manual Underwing Refuelling Nozzle – F116 Series

TESTING

1. General

Do all tests using Stoddard solvent (or equivalent) as the test fluid, supplied by a 0 to 120 psig test stand.

2. Functional Test

- A. Engage and lock the nozzle to the PORT C side of the test fixture (P/N F65-0-1130).
- B. Actuate the flow control handle five times. The valve must operate freely with no mechanical interference or binding. The flow control handle must rotate freely only when the nozzle is engaged and locked to the test fixture.

3. Leakage Test

- A. Engage and lock the nozzle or the coupler to the PORT A side of test fixture (P/N F65-0-1130).
- B. Install a matching test plug in the inlet port of the nozzle under test.
- C. Actuate the flow control handle and fill the adapter and the nozzle with test fluid, bleeding out the air through the test plug in the nozzle.
- D. Open and close the nozzle three times at pressures of 5, 60 and 120 PSIG. Hold each test pressure for one minute minimum.
- E. There must not be any external leakage through the nozzle body, past the shaft seals, or the nose seal, or evidence of any damage to the nozzle.
- F. Rotate the flow control handle to its CLOSED position. Unlock and disengage the nozzle from the test fixture.
- G. Pressurize the nozzle to 5, 60 and 120 PSIG. Hold each test pressure for one minute minimum. There must not be any leakage from the exterior of the nozzle, or from the nose plug.

USE OR DISCLOSURE OF DATA ON THIS PAGE IS SUBJECT TO THE RESTRICTIONS ON THE TITLE PAGE OF THIS DOCUMENT

01 Aug 2013

Revision 2.0

11

Meggitt Control Systems

Our product competencies & services:
Aerospace valves | Thermal management solutions | Environmental control systems | Electro-mechanical products
Ground fuelling products | Energy products | Aftermarket services

MEGGITT
smart engineering for
extreme environments

Energy products

Meggitt Fuelling Products Maintenance Manual Underwing Refuelling Nozzle – F116 Series

4. Vacuum Breaker Test (F116B Only)

A. Functional Test

1. Insert the vacuum breaker (IPL Figure 1, 46) in the nozzle body (54, 55 or 56), or a suitable test fixture.
2. Press the button (48) fully inward and then release it. The button must return to its normal position with no hang-up, chatter, or binding. The action must be free and smooth. Repeat this functional test three times.

B. Leakage Test

1. Pressurize the nozzle to 5, 60 and 120 PSIG. Hold each test pressure for one minute minimum. There must not be any leakage from the button end of the valve.

CAUTION

DO NOT OVER-TIGHTEN POPPET (47), SINCE THIS MAY RESTRICT THE AIR FLOW.

2. If leakage is observed during testing, remove the vacuum breaker and examine the packing (49) for damage, and check for contamination under the poppet (47). If the packing is in good condition, tighten the poppet a small amount and repeat the test as necessary until leakage stops.
3. If the packing (49) is damaged, replace it with a new packing. Then assemble, and repeat all of the vacuum breaker tests.

USE OR DISCLOSURE OF DATA ON THIS PAGE IS SUBJECT TO THE RESTRICTIONS ON THE TITLE PAGE OF THIS DOCUMENT



Energy products

Meggitt Fuelling Products Maintenance Manual Underwing Refuelling Nozzle – F116 Series

FAULT ISOLATION

1. General

This section contains fault isolation procedures for the nozzle. Operate the nozzle in accordance with the Operation section, if the nozzle fails to operate correctly refer to [Table 7](#) and select the appropriate action. [Table 7](#) identifies the Fault, Probable Cause and Corrective Action.

Table 7 Fault Isolation

FAULT	POSSIBLE CAUSE(S)	CORRECTIVE ACTION
Leakage at the poppet seat when closed	Damaged or worn seat (IPL Figure 1, 31)	Replace the seat.
	Damage or worn poppet (25 or 26)	Replace the poppet.
	Damaged or worn packing (30)	Replace the packing.
	Damaged or cracked nose on body (54, 55 or 56)	Replace the body.
	Damaged or cracked nose on body (56A or 56B)	Replace the connector insert (69 or 71).
	Poppet (25 or 26) incorrectly adjusted	Adjust the poppet.
Leakage past nose seal when coupled	Nose seal (28 or 67) damaged	Replace the nose seal.
	Mating flange and locking lugs on airplane fuel system inlet adapter damaged or worn	Use the adapter wear gage (P/N 2706128-101) to check the three locking lugs of the bayonet flange for wear, straightness, and alignment. If they are damaged, the airplane inlet adapter must be replaced.
Nozzle engages too tightly	Poppet (25 or 26) incorrectly	Adjust the poppet.

USE OR DISCLOSURE OF DATA ON THIS PAGE IS SUBJECT TO THE RESTRICTIONS ON THE TITLE PAGE OF THIS DOCUMENT



Meggitt Fuelling Products
Maintenance Manual
Underwing Refuelling Nozzle – F116 Series

	adjusted	
--	----------	--

USE OR DISCLOSURE OF DATA ON THIS PAGE IS SUBJECT TO THE RESTRICTIONS ON THE TITLE PAGE OF THIS DOCUMENT



Meggitt Fuelling Products
Maintenance Manual
Underwing Refuelling Nozzle – F116 Series

Table 7 Fault Isolation - (cont.)

FAULT	POSSIBLE CAUSE(S)	CORRECTIVE ACTION
Leakage past flow control handle shaft	Packing (37 or 38) damaged, twisted, or incorrectly installed	Replace the packimangs.
	Bearing (59 or 60) damaged or worn	Replace the bearings.

USE OR DISCLOSURE OF DATA ON THIS PAGE IS SUBJECT TO THE RESTRICTIONS ON THE TITLE PAGE OF THIS DOCUMENT

Meggitt Fuelling Products
Maintenance Manual
Underwing Refuelling Nozzle – F116 Series

REPAIR TASKS

1. Lubrication

Lightly lubricate all of the packings with petroleum jelly before installation.

2. Removing the Poppet (IPL Figure 1, 25 or 26)

- A. Remove the dust cap (5) from the nozzle.
- B. Compress the key ring (22) and rotate the shell grips (16).
- C. Rotate the flow control handle (34) to its OPEN position.
- D. Remove the cotter pin (24) and unscrew the poppet (25 or 26).

3. Adjusting the Poppet (IPL Figure 1, 25 or 26)

- A. Remove the poppet (25 or 26) in accordance with paragraph 2 above.

B. Initial Adjustment

With the flow control handle (34) at its fully OPEN position, screw the poppet (25 or 26) onto the rod (44) until the flow control handle cannot be rotated to its CLOSED position. Back the poppet outward until the flow control handle can just be rotated to its CLOSED position. Back the poppet out further, up to ½-turn, to align the holes for the cotter pin (24).

C. Checking the Poppet Adjustment

1. Insert the flange of the nose seal adjustment gage (P/N 2706112-102) in the nozzle and rotate the handles (10, 11, 12 or 13) to the connected position. The flow control handle (34) must remain in the closed position.
2. Insert plug of the nose seal adjustment gage (P/N 2706112-102) in the nozzle.
3. If the poppet adjustment is correct, the flange level will be between the surface marked "BELOW FLANGE" and the gage surface marked "ABOVE FLANGE." If the poppet adjustment is not correct, screw it inward or outward until it is correct, and then align the slot to install the cotter pin (24).

USE OR DISCLOSURE OF DATA ON THIS PAGE IS SUBJECT TO THE RESTRICTIONS ON THE TITLE PAGE OF THIS DOCUMENT



Energy products

Meggitt Fuelling Products Maintenance Manual Underwing Refuelling Nozzle – F116 Series

D. Install and form the cotter pin (24) to retain the poppet (25 or 26).

4. Replacing the Nose Seal Seat (IPL Figure 1, 31)

- A. Remove the poppet (25 or 26) in accordance with paragraph 2 above.
- B. Using two screwdrivers opposite each other, gently ease nose seal seat (31) from the nozzle body (54, 55, 56, 56A or 56B), using connector (17 or 20) as the fulcrum for the screwdrivers.
- C. Check the nozzle body (54, 55, 56, 56A or 56B) and the Belleville washer (32) for damage or excessive wear.
- D. Lubricate the packing (30) with petrolatum. Install the packing in the packing groove of the new nose seal seat (31). Install the new nose seal seat and the Belleville washer (32) in the nozzle body (54, 55, 56, 56A or 56B).

Note: The convex side of the Belleville washer (32) must be toward the nose of the nozzle as shown in [IPL Figure 1](#) to operate correctly.

5. Replacing the Nose Seal (IPL Figure 1, 28)

- A. Rotate the flow control handle (34) to its fully OPEN position to relieve tension on the nose seal (28).
- B. Carefully remove the spring (27) from the retainer (29).
- C. Using a screwdriver, gently pry the retainer (29) off of the nose seal seat (31), with the nose seal (28) installed.
- D. Remove the nose seal (28) from the retainer (29).
- E. Do not lubricate the new nose seal (28). Install the nose seal in the seal groove of the retainer (29).
- F. Lightly lubricate the inside diameter of the nose seal (28) with petrolatum. Do not allow the petrolatum to get between the seal and the retainer (29).
- G. Install the nose seal (28) and the retainer (29) on the nose seal seat (31) so that inner protrusion of its rubber rests on the lip of the seat.

Note: An old bayonet adapter flange can be used to install the nose seal.

USE OR DISCLOSURE OF DATA ON THIS PAGE IS SUBJECT TO THE RESTRICTIONS ON THE TITLE PAGE OF THIS DOCUMENT



Energy products

Meggitt Fuelling Products Maintenance Manual Underwing Refuelling Nozzle – F116 Series

- H. Use a flat plate to apply even pressure on the nose seal (28). The nose seal will snap into place on the nose seal seat (31).

CAUTION

THE POPPET SPRING (27) MUST NOT EXTEND BEYOND THE OUTSIDE DIAMETER OF THE RETAINER (29). THE ENDS OF THE SPRING MUST PASS THROUGH HOLES IN THE RETAINER AND ENTER GROOVE OF THE NOSE SEAL SEAT (31). DO NOT OVERSTRETCH SPRING.

- I. Insert the ends of the poppet spring (27) through holes in the groove of the retainer (29).

6. Replacing the Nose Seat-Seal (IPL Figure 1, 67)

- A. Remove the poppet (25 or 26) in accordance with paragraph 2 above.
- B. Using the special screwdriver (P/N 2707013), gently pry outward and downward on the retainer (29), starting at one end and working around until it is free of the nose-seal seat (31). Remove the nose seal-seat from the nozzle body (54, 55, 56, 56A or 56B).
- C. Check the nozzle body (54, 55, 56, 56A or 56B) and the Belleville washer (32) for damage or excessive wear. Check the retainer (29) for roundness or deformation. The retainer can be reformed to its round shape by hand.

Note: The convex side of the Belleville washer (32) must be toward the nose of the nozzle as shown in [IPL Figure 1](#) to operate correctly.

- D. Install the retainer (29) and the Belleville washer (32) on the new nose seal-seat (31). The retainer (29) shall be round and shall fit snugly on the nose seal-seat. Lubricate the packing (30) with petrolatum. Install the packing in the packing groove of the nose seal-seat.

CAUTION

DO NOT OVER-BEND THE RETAINER (29) DURING INSTALLATION. THE RETAINER MUST FIT SNUGLY AGAINST THE NOZZLE BODY (54, 55, 56, 56A OR 56B), WITH ITS LOWER LIP IN THE GROOVE OF THE NOZZLE BODY. THE NOSE SEAL-SEAT (31) MUST NOT BE LOOSEN THE NOZZLE BODY.

- E. Install the new nose seal-seat (31) with the retainer (29) and the Belleville washer (32) in the nozzle body (54, 55, 56, 56A or 56B). Gently pry the retainer (29) into its groove in the body, starting at one end and working around until it is fully engaged with the nose seal-seat and the nozzle body.

USE OR DISCLOSURE OF DATA ON THIS PAGE IS SUBJECT TO THE RESTRICTIONS ON THE TITLE PAGE OF THIS DOCUMENT

Energy products

Meggitt Fuelling Products Maintenance Manual Underwing Refuelling Nozzle – F116 Series

7. Replacing the Stop Screws (IPL Figure 1, 57)

- A. Remove the nuts (7), the washers (8), the bolts (9) and the handles (10, 11, 12 or 13) from the shell grips (16).
- B. Remove the screws (14), the washers (15) and the shell grips (16) from the connector (17, 17A or 20).
- C. Remove the screws (57) and the split ring (58) from the nozzle body (54, 55, 56, 56A or 56B).
- D. Inspect the key ring (22) and the shell grips (16). The wear surfaces must be smooth and free of gouges or pits which could cause tight engagement. Replace these parts if they are damaged. The key ring and the shell grips can be sprayed with dry-film lubricant. Do not use grease on these parts.
- E. Install the split ring (58) and the new screws (57) on the nozzle body (54, 55 or 56). Use a single strand of lockwire to safety wire the screws. Carefully tuck in the ends of the lockwire to prevent interference with the shell grips.
- F. Make sure the springs (23) and the key ring (22) or lock ring (22A) are correctly positioned. Install the shell grips (16) and secure them to the connector (17, 17A or 20) with the screws (14) and the washers (15). Safety wire the screws with lockwire.
- G. Install the handles (10, 11, 12 or 13) in the shell grips (16). Secure the handles with the nuts (7), the washers (8) and the bolts (9).

8. Replacing the Handle Shaft Packings (IPL Figure 1, 37 and 38)

- A. Rotate the flow control handle (34) to its fully OPEN position to relieve tension on the nose seal (28).
- B. Remove the cotter pin (24) and the washer (36) from the small end of the handle shaft (39).

Note: Note the orientation of the crank (42) with respect to the flow control handle (34), for assembly reference.
- C. Slowly pull the handle shaft (39) (with flow control handle attached to it) out of the nozzle body (54, 55, 56, 56A or 56B), and push a small rod or screwdriver in from the opposite end to retain the linkage. If linkage becomes uninstalled, refer to paragraph 8.H; steps 1 thru 6.

USE OR DISCLOSURE OF DATA ON THIS PAGE IS SUBJECT TO THE RESTRICTIONS ON THE TITLE PAGE OF THIS DOCUMENT

Energy products

Meggitt Fuelling Products Maintenance Manual Underwing Refuelling Nozzle – F116 Series

- D. Remove the small packing (37) from the handle shaft (39) and large packing (38) from the nozzle body (54, 55, 56, 56A or 56B) using a suitable pointed tool.
- E. Reinstall the flow control handle (34) and the handle shaft (39) in the nozzle body (54, 55, 56, 56A or 56B) with no packings or washers under the handle, but with the washers (35 and 36) and the cotter pin (24) installed.
- F. Using suitable feeler gages, measure the end play of the handle shaft (39). If the end play is more than 0.015 inch, remove the handle shaft and add washers (35 or 36) as required to reduce end play to less than 0.015 inch.

CAUTION

Make sure the packings are not twisted when they are installed in the packing grooves. Lubricate the packings well with petrolatum to avoid damaging them during installation.

- G. Install the small packing (37) on the handle shaft (39) and large packing (38) in the nozzle body (54, 55, 56, 56A or 56B), behind the bearing (59), using a pair of tweezers or similar suitable tool.
- H. Insert the handle shaft (39) with an easy twisting motion, slowly withdrawing the small rod or screwdriver.

Note: If the crank (42) and links (43) became uninstalled, proceed as follows:

1. Line up the links (43) so that their curved sides match the bulge in the side of the nozzle body (54, 55, 56, 56A or 56B).
2. Insert the handle shaft (39) with a twisting motion until it enters the crank (42) up to its hexagonal section.
3. Rotate the flow control handle (34) so that it points 90 degrees from the center of the nozzle body (54, 55, 56, 56A or 56B) in the OPEN position.
4. Pull the crank (42) upward from inside of the nozzle body (54, 55, 56, 56A or 56B) allowing the crank to hang vertically.
5. Slide the handle shaft (39) inward so that its hexagonal section enters the crank (42).
6. Push the handle shaft (39) into its fully installed position.

USE OR DISCLOSURE OF DATA ON THIS PAGE IS SUBJECT TO THE RESTRICTIONS ON THE TITLE PAGE OF THIS DOCUMENT

Energy products

Meggitt Fuelling Products Maintenance Manual Underwing Refuelling Nozzle – F116 Series

- I. Rotate the flow control handle to its OPEN position. Make sure the linkage operates freely and correctly.

9. Replacing the Clevis Pins (IPL Figure 1, 41) and the Links (43)

- A. Remove the poppet (25 or 26) in accordance with paragraph 2 above.
- B. Remove the cotter pins (24) and the clevis pins (41).
- C. Remove the shaft and linkage assembly (items 24, 41, 42, 43 and 44) from the nozzle body (54, 55, 56, 56A or 56B).
- D. Install the new links (43) and secure them with new clevis pins (41) and new cotter pins (24). Install the linkage and shaft assembly in the nozzle body (54, 55, 56, 56A or 56B).
- E. Adjust the poppet in accordance with paragraph 3 above.

10. Replacing the Bearings (IPL Figure 1, 59 and 60)

CAUTION

DO NOT CLAMP THE NOZZLE BODY TOO TIGHTLY OR IT MAY BECOME DEFORMED OR CRACKED.

- A. Carefully clamp the nozzle body (54, 55, 56, 56A or 56B) in a vise, so that the handle shaft boss faces upward.
- B. Using a 9/16-12NC tap, form three to four threads in the bearing (59) (just sufficient to grip the bearing).
- C. Thread a bolt into the bearing (59) and insert a rod into the hole in its other end. Gently tap the rod until bearing is removed.
- D. Remove the bearing (60), using a 7/16-14NC tap in a similar manner.
- E. Blow out all machining chips from the interior of the nozzle body (54, 55, 56, 56A or 56B) with compressed air.
- F. Carefully press new bearings (59 and 60) into the nozzle body (54, 55, 56, 56A or 56B), tapping them lightly with a plastic or rubber (not steel) mallet until they are fully shouldered.

USE OR DISCLOSURE OF DATA ON THIS PAGE IS SUBJECT TO THE RESTRICTIONS ON THE TITLE PAGE OF THIS DOCUMENT

Energy products

Meggitt Fuelling Products Maintenance Manual Underwing Refuelling Nozzle – F116 Series

- G. Check the alignment of the bearings (59 and 60) using the handle shaft (39) with no packings installed. Rotate the handle shaft several times to check for binding. If necessary, use the hand reamer (P/N C1-0-486) to align the bearings.

11. Replacing the Insert (IPL Figure 1, 69 or 71) (Mods X and Z only)

- A. Remove the poppet (25 or 26) in accordance with paragraph 2 above.
- B. Using two screwdrivers opposite each other, gently ease nose seal seat (31) from the nozzle body (56A or 56B), using connector (17 or 20) as the fulcrum for the screwdrivers.
- C. Check the nozzle body (56A or 56B) and the Belleville washer (32) for damage or excessive wear.
- D. Remove the nuts (7), the washers (8), the bolts (9) and the handles (10, 11, 12 or 13) from the shell grips (16).
- E. Remove the screws (14), the washers (15) and the shell grips (16) from the connector (17 or 20).
- F. Remove the screws (57) and the split ring (58) from the nozzle body (56A or 56B).
- G. Remove the packing (70) and the insert (69 or 71) from the nozzle body (56A or 56B).
- H. Install the new insert (69 or 71) and packing (70) in the nozzle body (56A or 56B).
- I. Install the split ring (58) and the new screws (57) on the nozzle body (56A or 56B). Torque the screws to 15 to 17 pound-inches. Use a single strand of lockwire to safety wire the screws. Carefully tuck in the ends of the lockwire to assure proper sealing and to prevent interference with the shell grips.
- J. Make sure the springs (23) and the key ring (22) are correctly positioned. Install the shell grips (16) and secure them to the connector (17, 17A or 20) with the screws (14) and the washers (15). Secure the screws (14) with lockwire.
- K. Install the handles (10, 11, 12 or 13) in the shell grips (16). Secure the handles with the nuts (7), the washers (8) and the bolts (9).
- L. Install the nose seal (28) in accordance with paragraph 5 above.

USE OR DISCLOSURE OF DATA ON THIS PAGE IS SUBJECT TO THE RESTRICTIONS ON THE TITLE PAGE OF THIS DOCUMENT

Energy products

Meggitt Fuelling Products Maintenance Manual Underwing Refuelling Nozzle – F116 Series

CLEANING

1. Cleaning Materials

Refer to [Table 8](#) for recommended cleaning materials. Suitable equivalent cleaning materials shall be substituted for the items listed.

Table 8 Recommended Cleaning Materials

DESCRIPTION	SPECIFICATION	SOURCE
Brush, Bristle, stiff, nonmetallic	–	Commercially available
Dry Cleaning Solvent	P-D-680, Type 2	Commercially available
Pick, Teflon	–	Commercially available
Plastic Bags	–	Commercially available
Tissues, lint-free	–	Commercially available

2. Cleaning Procedures



WARNING DRY CLEANING SOLVENT IS A HAZARDOUS MATERIAL. BEFORE USE, READ AND OBEY THE MATERIAL SAFETY DATA SHEET (MSDS) INSTRUCTIONS FOR CORRECT HANDLING. FAILURE TO OBEY THIS WARNING MAY RESULT IN PERSONAL INJURY, LONG TERM HEALTH HAZARDS OR DEATH.

- A. Clean all metal parts by washing thoroughly in dry cleaning solvent. Remove stubborn deposits by scrubbing with a nonmetallic stiff bristle brush. Brush all threaded areas. Use a Teflon pick to remove obstructions from the ports, the seal or packing grooves and the flow passages.
- B. Make sure the flow passage of the nozzle body ([IPL Figure 1](#), 54, 55, 56, 56A or 56B) is clean, especially where the plug (45) is installed.

Note: All parts must be free of corrosion, dirt, grease, oil or any other foreign matter.

USE OR DISCLOSURE OF DATA ON THIS PAGE IS SUBJECT TO THE RESTRICTIONS ON THE TITLE PAGE OF THIS DOCUMENT

Energy products

Meggitt Fuelling Products Maintenance Manual Underwing Refuelling Nozzle – F116 Series



WARNING

WEAR EYE PROTECTION WHEN USING COMPRESSED AIR AND DO NOT DIRECT AIRSTREAM AT PERSONNEL OR LIGHT METAL PARTS.

- C. Dry the parts with clean lint-free tissues or clean, dry, compressed air.
- D. Package all of the clean parts in plastic bags.

USE OR DISCLOSURE OF DATA ON THIS PAGE IS SUBJECT TO THE RESTRICTIONS ON THE TITLE PAGE OF THIS DOCUMENT

01 Aug 2013

Revision 2.0

24

Meggitt Control Systems

Our product competencies & services:
Aerospace valves | Thermal management solutions | Environmental control systems | Electro-mechanical products
Ground fuelling products | Energy products | Aftermarket services

MEGGITT
smart engineering for
extreme environments

Energy products

Meggitt Fuelling Products Maintenance Manual Underwing Refuelling Nozzle – F116 Series

CHECK/INSPECTION

1. General

Under strong light and magnification, look at all parts in accordance with the general criteria specified in paragraph 2.

Repair minor damage in accordance with instructions presented in the REPAIR section. If damage is major or beyond simple repair, replace the part rather than attempt extensive repairs.

2. Component Checks (Table 9)

Table 9 Component Checks

DESCRIPTION (IPL Figure 1 Item No.)	INSPECTION CRITERIA
General	<p>Look at all parts as applicable for nicks, cracks, cuts, burrs, corrosion, breaks, scoring, deformation, dents, thread damage, or any other obvious defects.</p> <p>Make sure the ports, passages, recesses and sealing grooves are clean and unobstructed</p> <p>Check all sealing and seating surfaces for damage or corrosion which would affect sealing.</p>
Machine Screws (9, 14, 52 and 57)	<p>Check for burrs, excessive wear, and straightness.</p> <p>Replace the screws if damaged. Do not attempt to repair them.</p>
Connector (17 or 17A)	<p>Using a dial indicator, check for wear on the lug engagement face in three places as shown in Figure 2, Sheet 1. If the wear is greater than 0.031 inch (0.78 mm), replace the connector.</p> <p>Check the corner wear radius on the three corners as shown in Figure 2, Sheet 1. If any corner radius is worn to more than 0.078 inch (1.98 mm), replace the connector.</p>
Connector (20)	<p>Using a dial indicator, check for wear on the lug engagement face in three places as shown in Figure 2, Sheet 2. If the wear is greater than 0.031 inch (0.78 mm), replace the connector.</p>

USE OR DISCLOSURE OF DATA ON THIS PAGE IS SUBJECT TO THE RESTRICTIONS ON THE TITLE PAGE OF THIS DOCUMENT

01 Aug 2013

Revision 2.0

25

Meggitt Control Systems

Our product competencies & services:
Aerospace valves | Thermal management solutions | Environmental control systems | Electro-mechanical products
Ground fuelling products | Energy products | Aftermarket services

MEGGITT
smart engineering for
extreme environments

Energy products

Meggitt Fuelling Products Maintenance Manual Underwing Refuelling Nozzle – F116 Series

Table 9 Component Checks (Cont.)

DESCRIPTION (IPL Figure 1 Item No.)	INSPECTION CRITERIA
Connector (20) (continued)	<p>Check the corner wear radius on the three setscrews as shown in Figure 2, Sheet 1. If any corner radius is worn to more than 0.062 inch (1.57 mm), replace the connector.</p> <p>The face of the setscrew must be flush with the surface as shown in Figure 2, Sheet 2, within ± 0.005 inch (± 0.13 mm). (The setscrew can be replaced if damaged or excessively worn.)</p>
Springs (23)	<p>If the free length of a spring is less than 0.850 inch (21.6 mm), replace the spring.</p> <p>If a spring is not straight or is deformed, replace the spring.</p>
Flow Control Handle (34)	Check for sharp edges and abrasive wear.
Handle Shaft (39)	<p>The surface finish in the bearing areas must be smooth.</p> <p>Roll the shaft on a flat surface to check straightness. The shaft must be straight.</p> <p>Check for abrasive wear on the ends of the shaft.</p> <p>Check for cracks at the cross holes.</p>
Rod (44)	<p>Check the pin hole in the threaded end of the rod for cracks.</p> <p>Replace the rod if cracks are found.</p>
Nozzle Body (54, 55, 56)	<p>Check the shaft holes in the body for burrs where the packings enter. Remove any burrs.</p> <p>Check for excessive wear of the sacrificial bosses at the handle shaft.</p> <p>Check for cracks at all of the holes in the body. Replace the body if any cracks are found.</p> <p>Check for cracks where the nose for the seat (31 or 67) joins the main body. Replace the body if any cracks are found.</p>
Nozzle Body (56A or 56B)	<p>Check the shaft holes in the body for burrs where the packings enter. Remove any burrs.</p> <p>Check for excessive wear of the sacrificial bosses at the handle shaft.</p>

USE OR DISCLOSURE OF DATA ON THIS PAGE IS SUBJECT TO THE RESTRICTIONS ON THE TITLE PAGE OF THIS DOCUMENT



Energy products

Meggitt Fuelling Products Maintenance Manual Underwing Refuelling Nozzle – F116 Series

Table 9 Component Checks (cont.)

DESCRIPTION (IPL Figure 1 Item No.)	INSPECTION CRITERIA
Nozzle Body (56A or 56B) <i>(continued)</i>	Check for cracks at all of the holes in the body. Replace the body if any cracks are found.
Bearings (59 and 60)	If the handle shaft (39) can be moved up and down more than 0.001 inch total, replace both of the bearings.

USE OR DISCLOSURE OF DATA ON THIS PAGE IS SUBJECT TO THE RESTRICTIONS ON THE TITLE PAGE OF THIS DOCUMENT

01 Aug 2013

Revision 2.0

27

Meggitt Control Systems

Our product competencies & services:
Aerospace valves | Thermal management solutions | Environmental control systems | Electro-mechanical products
Ground fuelling products | Energy products | Aftermarket services

MEGGITT
smart engineering for
extreme environments

Meggitt Fuelling Products
Maintenance Manual
Underwing Refuelling Nozzle – F116 Series

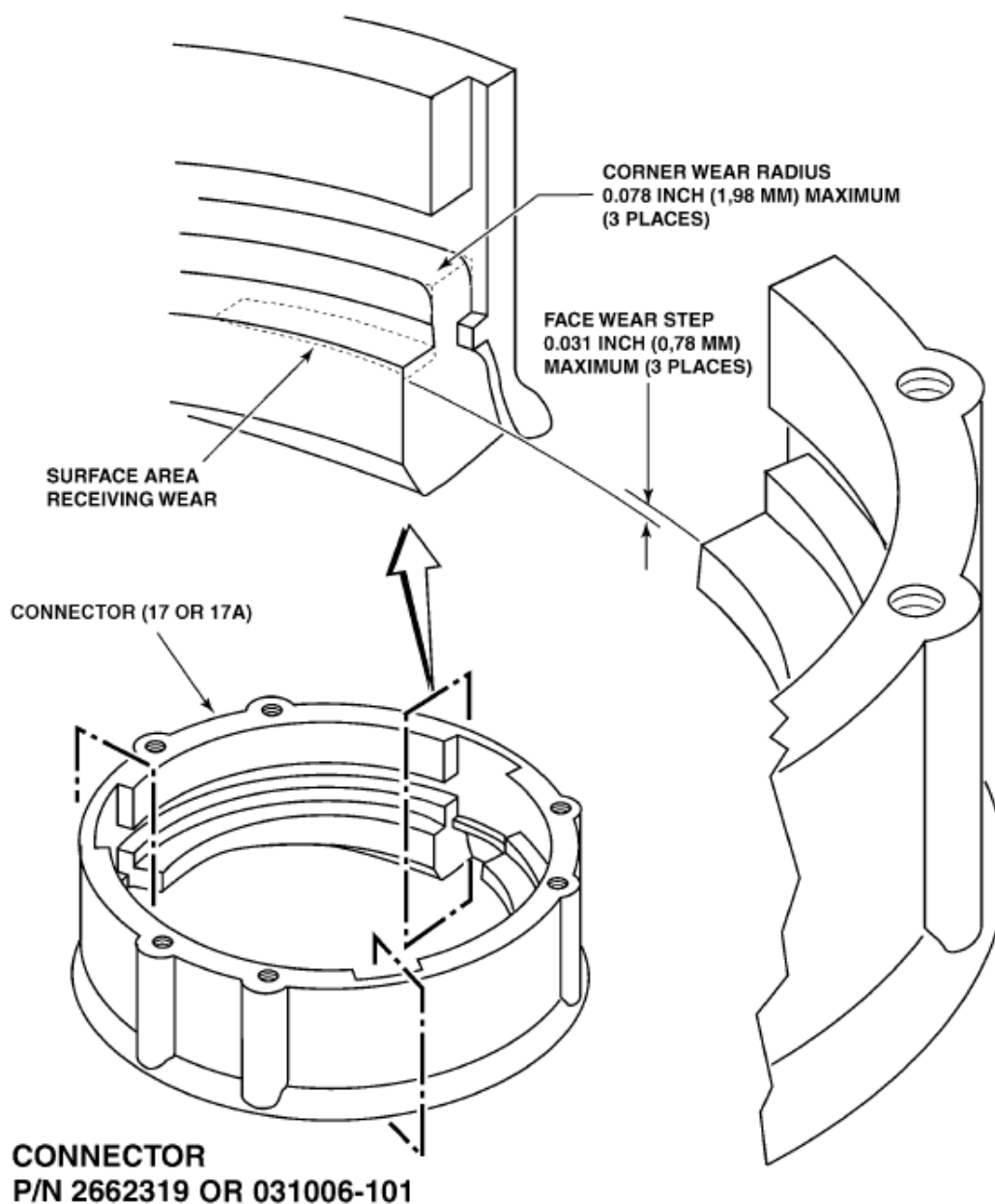

Figure 2. Connector Wear Limits (Sheet 1 of 2)

USE OR DISCLOSURE OF DATA ON THIS PAGE IS SUBJECT TO THE RESTRICTIONS ON THE TITLE PAGE OF THIS DOCUMENT

Energy products

Meggitt Fuelling Products Maintenance Manual Underwing Refuelling Nozzle – F116 Series

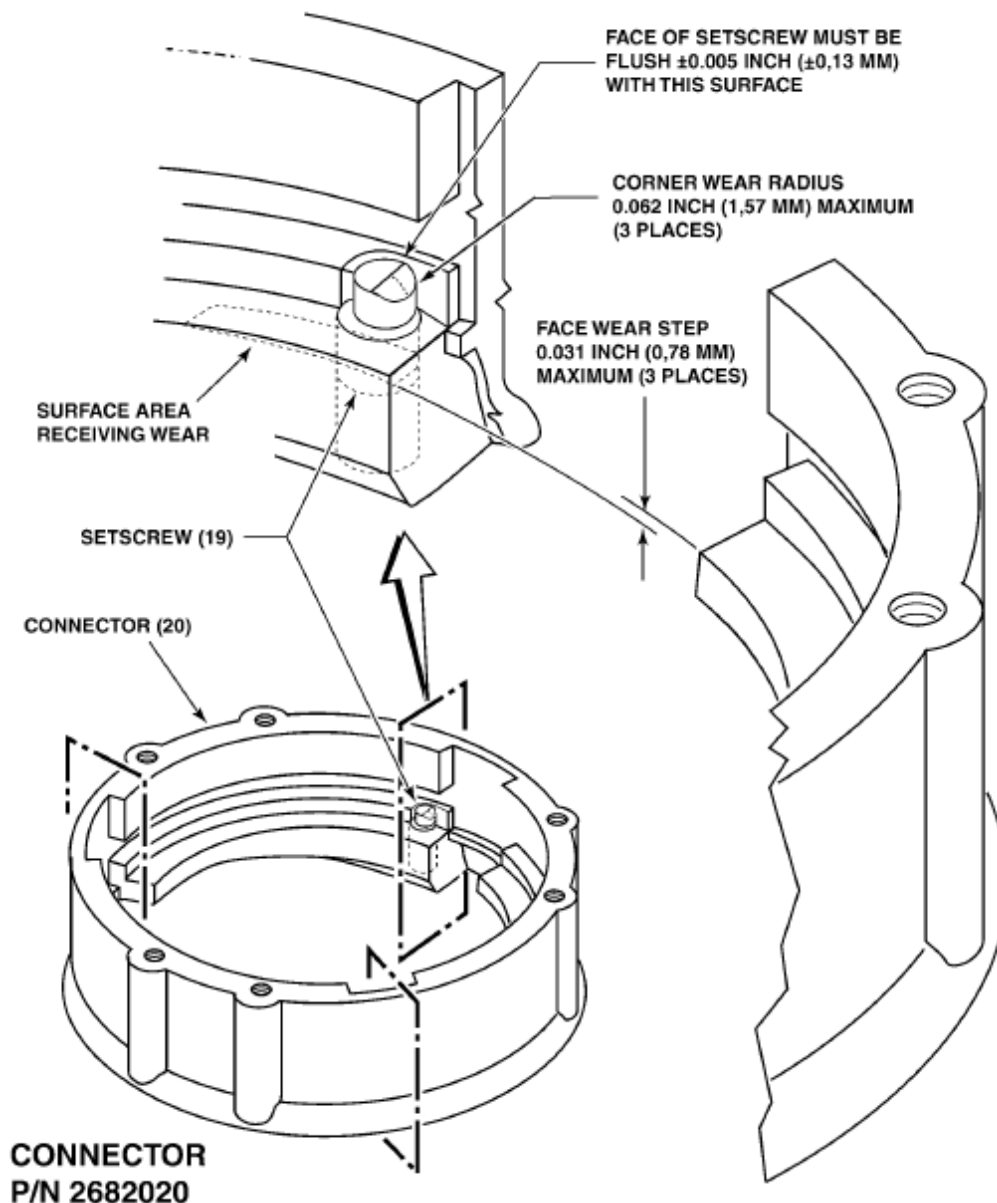

Figure 2. Connector Wear Limits (Sheet 2)

USE OR DISCLOSURE OF DATA ON THIS PAGE IS SUBJECT TO THE RESTRICTIONS ON THE TITLE PAGE OF THIS DOCUMENT

01 Aug 2013

Revision 2.0

29

Meggitt Control Systems

Our product competencies & services:
Aerospace valves | Thermal management solutions | Environmental control systems | Electro-mechanical products
Ground fuelling products | Energy products | Aftermarket services

MEGGITT
smart engineering for
extreme environments

Energy products

Meggitt Fuelling Products Maintenance Manual Underwing Refuelling Nozzle – F116 Series

ILLUSTRATED PARTS LIST

1. General

This section lists, describes, and illustrates all detail parts required for maintenance support of the Underwing Refueling Nozzle.

2. Scope of Information

The parts list is arranged in the general order of disassembly. The listing is indented to show the relationship between each part and its next higher assembly. Item numbers used in the parts list are keyed to the corresponding numbers of the accompanying illustration.

A. MODIFICATION CODE

The modification code indicates the parts usage with respect to the end item. When the MOD column is blank, the part usage is applicable to all versions unless otherwise specified in the DESCRIPTION column.

B. How to Identify a Part

When the part number is known: Refer to the parts list for the item number, description, modification codes, and quantity. Refer to the illustration to make sure of the physical appearance and location of the part.

When the part number is not known: Examine the illustrations to identify the part by physical appearance and location. Refer to the accompanying parts list to get the part number, nomenclature, modification codes, quantity, etc.

C. Abbreviations

ASSY	Assembly
FIG.	Figure
HECV	Hose End Control Valve
IPL	Illustrated Parts List
MOD	Modification

USE OR DISCLOSURE OF DATA ON THIS PAGE IS SUBJECT TO THE RESTRICTIONS ON THE TITLE PAGE OF THIS DOCUMENT

Energy products

Meggitt Fuelling Products Maintenance Manual Underwing Refuelling Nozzle – F116 Series

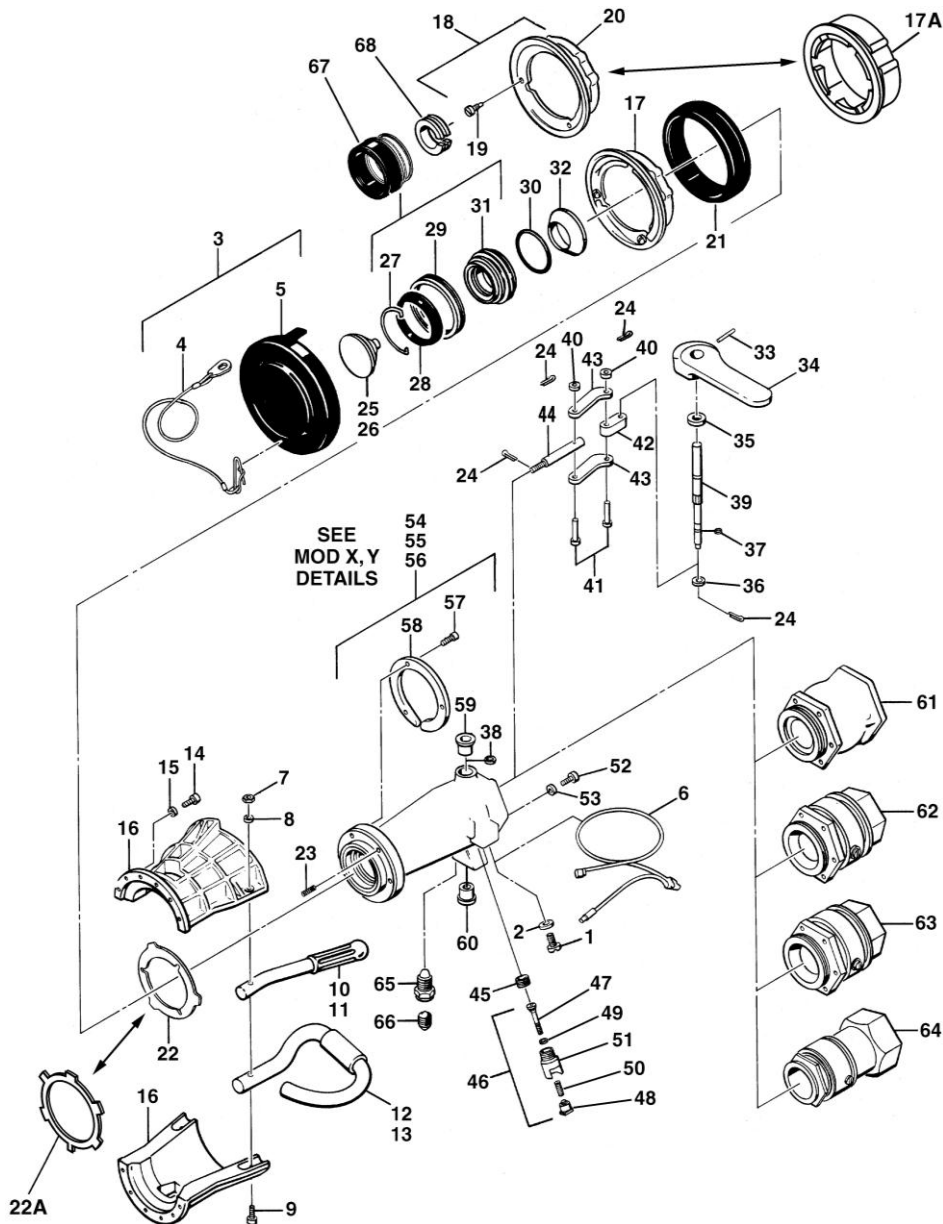

IPL Figure 1. Underwing Refueling Nozzle (Sheet 1 of 2)

USE OR DISCLOSURE OF DATA ON THIS PAGE IS SUBJECT TO THE RESTRICTIONS ON THE TITLE PAGE OF THIS DOCUMENT

01 Aug 2013

Revision 2.0

31

Meggitt Control Systems

Our product competencies & services:
Aerospace valves | Thermal management solutions | Environmental control systems | Electro-mechanical products
Ground fuelling products | Energy products | Aftermarket services

MEGGITT
smart engineering for
extreme environments

Energy products

Meggitt Fuelling Products Maintenance Manual Underwing Refuelling Nozzle – F116 Series

MOD X

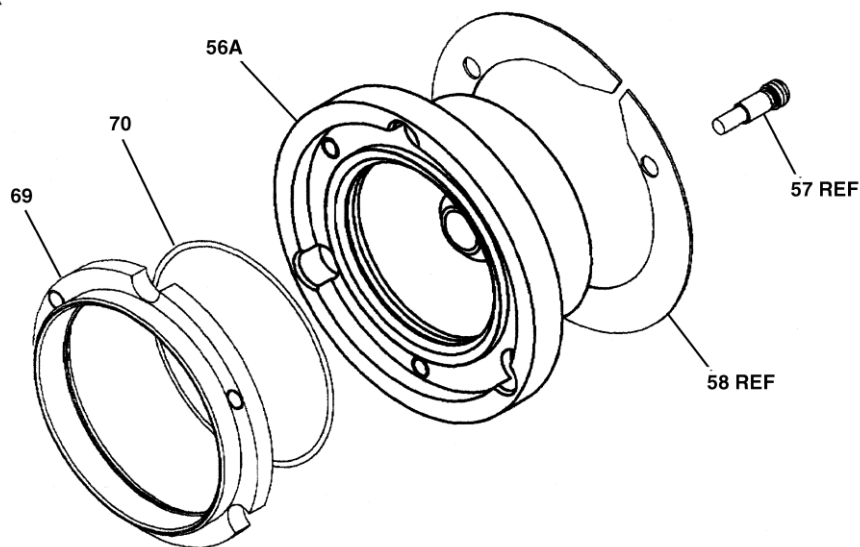

MOD Z

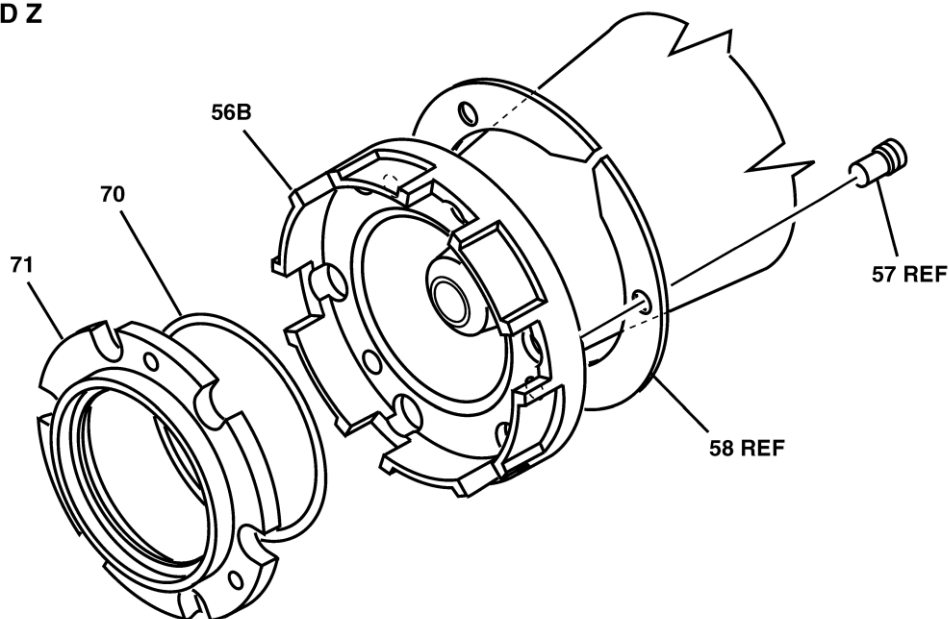

IPL Figure 1. Underwing Refueling Nozzle (Sheet 2)

USE OR DISCLOSURE OF DATA ON THIS PAGE IS SUBJECT TO THE RESTRICTIONS ON THE TITLE PAGE OF THIS DOCUMENT

Energy products

Meggitt Fuelling Products Maintenance Manual Underwing Refuelling Nozzle – F116 Series

FIG. ITEM	PART NUMBER	DESCRIPTION	MOD CODES	UNITS PER ASSY
NOZZLE, UNDERWING REFUELING				
1				
1	CAN501D616-8	. SCREW, MACHINE		1
2	CMS35338-141	. WASHER, LOCK.....		1
3	F62W7504	. COVER ASSEMBLY, DUST		1
4	1426-595145	. . CABLE		1
5	F62W7503	. . COVER, DUST.....		1
6	2671893	. CABLE, GROUNDING	A	1
7	CMS20364-428C	. NUT, SELF-LOCKING		2
8	CMS35338-139	. WASHER, LOCK.....		2
9	CAN4C13	. BOLT, MACHINE		2
10	1426-586133	. HANDLE, BICYCLE		2
11	1426-595133	. HANDLE, BICYCLE (LONG) (REPLACES ITEM 10)	D	2
12	F59F1377	. HANDLE, STIRRUP (RH) (REPLACES ITEM 10)	C	1
13	F59F1378	. HANDLE, STIRRUP (LH) (REPLACES ITEM 10)	C	1
14	CMS35275-265	. SCREW, MACHINE		6
15	MS35338-138	. WASHER, LOCK.....		6
16	2671769	. GRIP, SHELL		2
16A	2671769-101	. GRIP, SHELL (Blue)	Z	2
17	2662319	. CONNECTOR		1
17A	031006-101	. CONNECTOR (6-Slot)	Z	1
18	2682020	. CONNECTOR ASSEMBLY (REPLACES ITEM 17)	J	1
19	2701615	. . SETSCREW.....	J	3
20	2682020-1	. . CONNECTOR.....	J	1
21	7-449-16	. RING, SCUFF		1
22	F61F1363	. RING, KEY		1
22A	031007	. RING, LOCK.....	Z	1

* = Suggested spare part

+ = Item not illustrated

USE OR DISCLOSURE OF DATA ON THIS PAGE IS SUBJECT TO THE RESTRICTIONS ON THE TITLE PAGE OF THIS DOCUMENT

01 Aug 2013

Revision 2.0

33

Meggitt Control Systems

Our product competencies & services:
Aerospace valves | Thermal management solutions | Environmental control systems | Electro-mechanical products
Ground fuelling products | Energy products | Aftermarket services

MEGGITT
smart engineering for
extreme environments

Energy products

Meggitt Fuelling Products
Maintenance Manual
Underwing Refuelling Nozzle – F116 Series

FIG. ITEM	PART NUMBER	DESCRIPTION	MOD CODES	UNITS PER ASSY
NOZZLE, UNDERWING REFUELING				
1 23	7410-585771	. SPRING, COMPRESSION	Z	3
	7410-585771	. SPRING, COMPRESSION		6
24	2706782-3-10	. PIN, COTTER		4
25	2713550-2	. POPPET		1
26	2713550-1	. POPPET (FOR F110/F115 CONVERSIONS ONLY) (MATES WITH 1426-585772 ROD)		1
27	1426-585770	. SPRING, POPPET		1
28	2662383-2	. SEAL (3 RAISED DOTS)		1
29	4631036	. RETAINER		1
30	2661058A145	. PACKING, PREFORMED		1
31	2701911	. SEAT, POPPET SEAL		1
32	2642886	. WASHER, BELLEVILLE		1
33	219-1375-HCP	. PIN, SPRING		1
34	4631059-2	. HANDLE, FLOW CONTROL		1
35	CAN960PD816L	. WASHER, FLAT		1
36	CAN960C616L	. WASHER, FLAT		1
37	2661058A010	. PACKING, PREFORMED		1
38	2661058A014	. PACKING, PREFORMED		1
39	2633284	. SHAFT, HANDLE		1
40	CAN960C516L	. WASHER, FLAT		2
41	CMS20392-4C29	. PIN, CLEVIS		2
42	2701173	. CRANK		1
43	F61F1307	. LINK		2
44	2713659	. ROD, POPPET		1
45	CMS20913-3CR	. PLUG (1 REQUIRED FOR 2681430-1 Body)		2
46	F509	. BREAKER ASSEMBLY, VACUUM (REPLACES ITEM 45)	B	1
47	1429-595063	. . POPPET	B	1

* = Suggested spare part

+ = Item not illustrated

USE OR DISCLOSURE OF DATA ON THIS PAGE IS SUBJECT TO THE RESTRICTIONS ON THE TITLE PAGE OF THIS DOCUMENT

01 Aug 2013

Revision 2.0

34

Meggitt Control Systems

Our product competencies & services:
Aerospace valves | Thermal management solutions | Environmental control systems | Electro-mechanical products
Ground fuelling products | Energy products | Aftermarket services

MEGGITT
smart engineering for
extreme environments

Energy products

Meggitt Fuelling Products
Maintenance Manual
Underwing Refuelling Nozzle – F116 Series

FIG. ITEM	PART NUMBER	DESCRIPTION	MOD CODES	UNITS PER ASSY
NOZZLE, UNDERWING REFUELING				
1 48	1429-586169	. . BUTTON	B	1
49	2661058A010	. . PACKING, PREFORMED	B	1
50	1429-586171	. . SPRING, COMPRESSION	B	1
51	1429-595064	. . BODY, BREAKER	B	1
52	CMS35276-280	. SCREW, MACHINE		6
53	CMS35338-139	. WASHER, LOCK		6
54	2681430-4	. BODY ASSEMBLY, NOZZLE		1
	2681430-1	. BODY ASSEMBLY, NOZZLE (ALTERNATE)		1
55	2681430-2	. BODY ASSEMBLY, NOZZLE	M,Y	1
56	2681430-3	. BODY ASSEMBLY, NOZZLE	M,Z	1
56A	2681430-5	. BODY ASSEMBLY, NOZZLE	X	1
56B	2681430-7	. BODY ASSEMBLY, NOZZLE	Z	1
57	2662382	. . SCREW, STOP		3
	031005	. . SCREW, MACHINE	Z	3
58	F61F1364	. . RING, SPLIT		1
59	SLF517-10	. . BEARING		1
	FF620-7	. . BEARING (Alternate)		1
60	SLF384-11	. . BEARING		1
	FF503-4	. . BEARING (ALTERNATE)		1
61	F595	. VALVE, HOSE END CONTROL (REFER TO MANUAL F594/F595)	E,G,H,L	1
62	F575/F584	. SWIVEL ASSEMBLY (3-INCH STRAINER) (REFER TO MANUAL F575)		1
63	F577/F582	. SWIVEL ASSEMBLY (2-INCH STRAINER) (REFER TO MANUAL F575/F577)		1
64	F596/F1516	. DISCONNECT, DRY		1
65	2706054-101	. GAGE, PRESSURE (100 PSI)	M	1
66	CMS20913-4	. PLUG	Y	1
67	2713509	. SEAL, NOSE (Flexible)	N	1
68	2671843	. RETAINER	N	1

* = Suggested spare part

+ = Item not illustrated

USE OR DISCLOSURE OF DATA ON THIS PAGE IS SUBJECT TO THE RESTRICTIONS ON THE TITLE PAGE OF THIS DOCUMENT

01 Aug 2013

Revision 2.0

35

Meggitt Control Systems

Our product competencies & services:

Aerospace valves | Thermal management solutions | Environmental control systems | Electro-mechanical products
Ground fuelling products | Energy products | Aftermarket services

MEGGITT
smart engineering for
extreme environments

Energy products

Meggitt Fuelling Products
Maintenance Manual
Underwing Refuelling Nozzle – F116 Series

FIG. ITEM	PART NUMBER	DESCRIPTION	MOD CODES	UNITS PER ASSY
NOZZLE, UNDERWING REFUELING				
1 69	981062-102	. INSERT, CONNECTOR	X	1
	GTP1128S	. INSERT, CONNECTOR (ALTERNATE)	X	1
70	2661058A039	. PACKING, PREFORMED	X,Z	1
71	031003	. INSERT, CONNECTOR (6-SLOT)	Z	1

* = Suggested spare part

+ = Item not illustrated

NOZZLE OVERHAUL PARTS KITS AVAILABLE		
KIT PART NUMBER	APPLICABLE TO	ITEMS IN KIT (IPL Figure 1)
KITF116-1	F116 (Basic)	24, 27, 28, 30, 31, 33, 36, 37, 38 + 2661058A042 packing for inlet flange
KITF116-3	F116 with F575/F584 swivel	24, 27, 28, 30, 31, 33, 36, 37, 38 + 2661058A042 packing for inlet flange + Q4235-366Y seal for swivel
KITF116-4	F116 with F577/F582 swivel	24, 27, 28, 30, 31, 33, 36, 37, 38 + 2661058A042 packing for inlet flange + Q4231-366Y seal for swivel
KITF116-5	F116 with F581 swivel	24, 27, 28, 30, 31, 33, 36, 37, 38 + 2661058A042 packing for inlet flange + 2661058A042 packing and Q4235-366Y seal for swivel

NOZZLE CONVERSION PARTS KIT AVAILABLE		
KIT PART NUMBER	APPLICABLE TO	ITEMS IN KIT (IPL Figure 1)
KITF115-11*	F110 and F115	24, 26, 27, 28, 29, 30, 31 (The cotter pin hole in the rod must be drilled out to 0.096 inch diameter.)

*For conversion of the nose seal and poppet to the F116 type, using the existing rod (1426-585772) with 5/16-inch threads.

USE OR DISCLOSURE OF DATA ON THIS PAGE IS SUBJECT TO THE RESTRICTIONS ON THE TITLE PAGE OF THIS DOCUMENT

01 Aug 2013

Revision 2.0

36

Meggitt Control Systems

Our product competencies & services:
Aerospace valves | Thermal management solutions | Environmental control systems | Electro-mechanical products
Ground fuelling products | Energy products | Aftermarket services

MEGGITT
smart engineering for
extreme environments