

EURO-Line Bottom Valves

CIVACON's EURO100-Line Bottom Valves are designed for increased safety, durability and service performance. The EURO100-Line high flow bottom valves are available as Compact 100-1 series, Super Compact 100-2 series, 4" TTMA or TW 100-3 series and T-Shape 100-4 series.



EURO100-1 series

Features and Benefits

- **All EURO100-Line Bottom Valves** in accordance with EN13308 (Non Pressure Balanced), EN13316 (Pressure Balanced), ADR and API RP 1004
- **Available models:** Compact, Super Compact, 4" TTMA or TW outlet and T-Shape
- **Pressure balanced** or non pressure balanced operation
- **Sequenced** or non-sequenced operation
- **4" or DN100** connection
- **Lightweight pressure** die-cast for improved strength and reduced weight
- **Hard anodized** and stainless steel internals
- **Stainless steel** filter/strainer
- **Shear Groove** to prevent spillage in case of an accident
- **Superior flow rate:**
 - up to 2.500 litres/minute
 - no moving parts in the flow path
- **Viton GLFT seals**
- **Valve service** inside of the compartment
- **Manually openable** in case of emergency

Specifications

1.5.

EURO100-1 SERIES

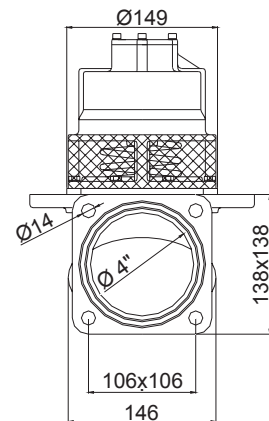
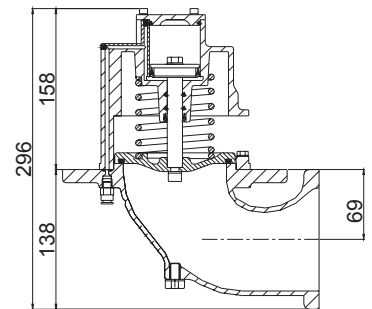
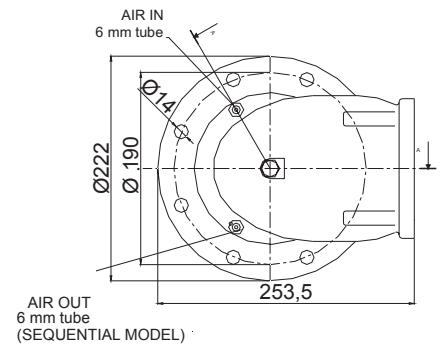

General specifications

- Nominal size 4" or DN 100
- Working pressure 5 bar (500 kPa)
- Operating air pressure 4 bar
- Maximum flow rating 2.500 litre/minute
- Seals Viton GFLT
- Working temperature -20 °C to 70 °C
other temperatures on request
- Weight EURO100-1 4,6 kg
EURO100-2 5,5 kg
EURO100-3 4,7 kg
EURO100-4 5,8 kg

Airport components

C/Nicolás de Bussi 20 Elche Parque Empresarial 03203
Elche, Alicante (Spain)
Tel +34 965 463 463

Specifications

EURO100-2 SERIES

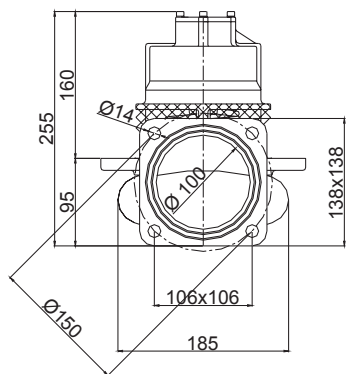
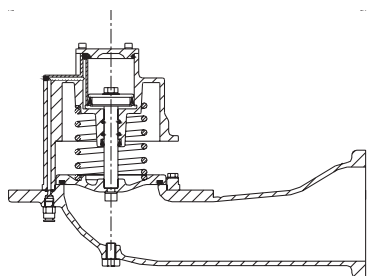
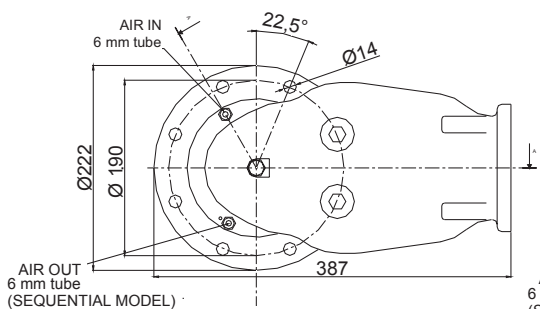

EURO100-3 SERIES

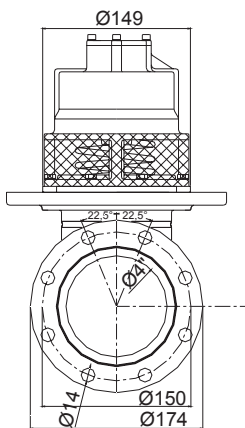
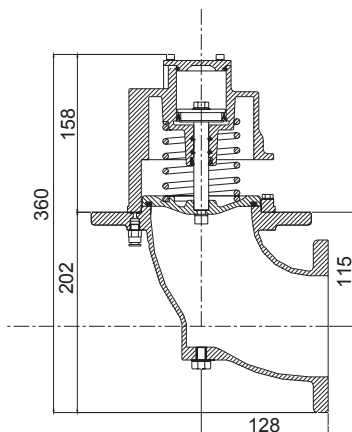
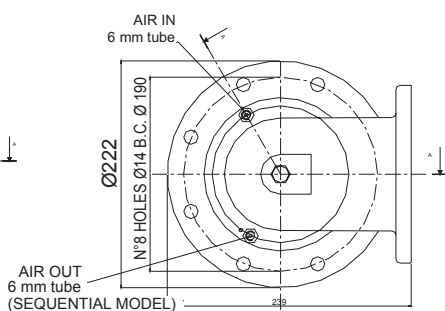

EURO100-4 SERIES

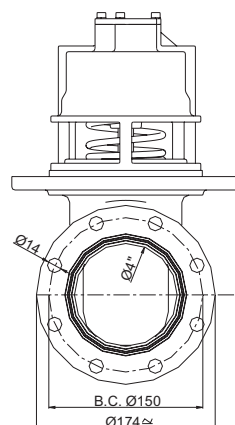
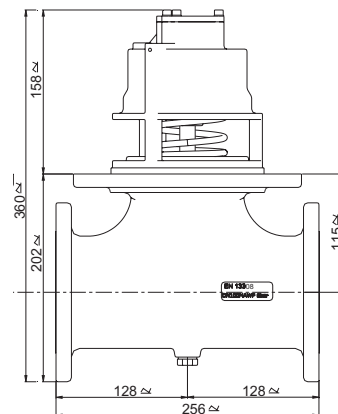
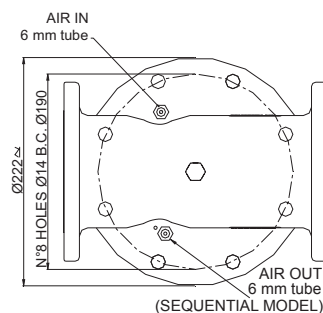

EURO-Line Bottom Valves

Spare parts

Repair kit

EURO100RK Seal kit for EURO100-series
Bottom Valve

Contents EURO100RK Repair kit

Item	Part number	Description
1	89-60-75/V	O-ring (Viton)
2	26-60-27	Gasket (Viton)
3	26-60-26	O-ring (Viton)
4	82-30-53	Gasket (Viton)
5	89-60-76/V	O-ring (Viton)
6	92-60-70	O-ring (Viton)

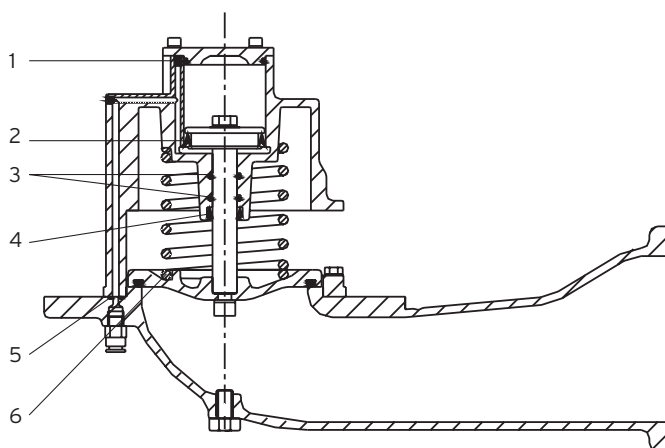

Related products

Art. number	Description
SF-100-ST40	Steel sump flange
10-02-43	Aluminium sump flange
10-01-74/EU	Aluminium square outlet flange
10-01-84	Gasket for square outlet flange

Ordering specifications

Compact Model: EURO100-1 series

EURO100-1-AL40	4" non-pressure balanced, non sequenced
EURO100-1S-AL40	4" non-pressure balanced, sequenced
EURO100-1B-AL40	4" pressure balanced, non sequenced
EURO100-1BS-AL40	4" pressure balanced, sequenced

Super Compact Model: EURO100-2 series

EURO100-2-AL40	4" non-pressure balanced, non sequenced
EURO100-2S-AL40	4" non-pressure balanced, sequenced
EURO100-2B-AL40	4" pressure balanced, non sequenced
EURO100-2BS-AL40	4" pressure balanced, sequenced

4" TTMA Outlet Model: EURO100-3 series

EURO100-3-AL40	4" non-pressure balanced, non sequenced
EURO100-3S-AL40	4" non-pressure balanced, sequenced
EURO100-3B-AL40	4" pressure balanced, non sequenced
EURO100-3BS-AL40	4" pressure balanced, sequenced

4" T-Shape Model: EURO100-4 series

EURO100-4-AL40	4" non-pressure balanced, non sequenced
EURO100-4S-AL40	4" non-pressure balanced, sequenced
EURO100-4B-AL40	4" pressure balanced, non sequenced
EURO100-4BS-AL40	4" pressure balanced, sequenced

