

3" DN80 Sequential Support Valve

Art. 652000



CHARACTERISTICS:

Complies with specification of order number 24340 of October 16th 1996 of the Ministry of Industry and Energy.

Pneumatic command.

Can be mounted vertically or horizontally.

Body pressure tested at 500 KPa.

MATERIALS:

Body and components in treated lightweight aluminium alloy.

Axle and spring in stainless steel.

Gaskets in fluoroelastomer / Nitrile.

Weight: 1,65 Kg

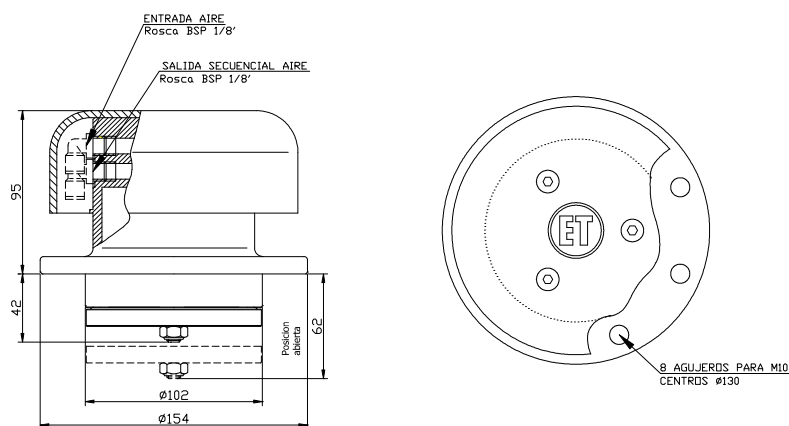

3" DN80 Sequential Support Valve

Art. 652000

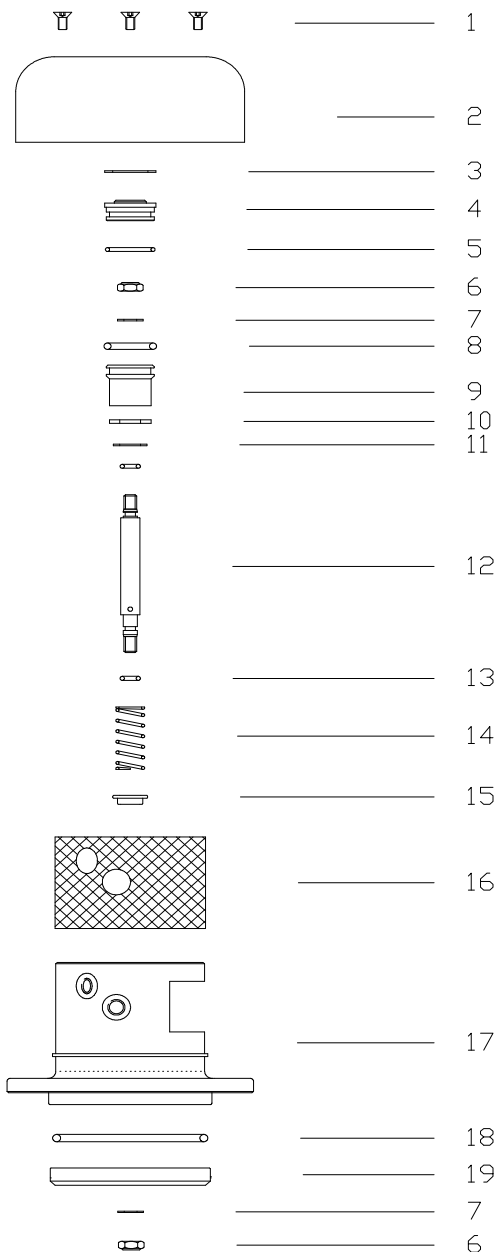

Fig.	Qty.	Description	Art.
1	3	Screw	650008
2	1	Proteccion hood	650005
3	1	Seeger butt	600051
4	1	Butt	600017
5	1	Butt gasket	600042
6	2	Self locking nut	600055
7	2	Self locking nut washer	600032
8	1	Sequential piston o-ring	600044
9	1	Sequential piston	600047
10	1	Piston flat gasket	600048
11	1	Flat gasket washer	600034
12	2	Axle gasket	600041
13	1	Sequential piston axle	650011
14	1	Spring	600025
15	1	Housing guide	600020
16	1	Flame arrester	650070
17	1	Body	650001
18	1	Closing gasket	600040
19	1	Closing saucer	600005

ACCESSORIES

Flange gasket	Art. 650091
Flange	Art. 650090