

4 LITRE CLOSED CIRCUIT SAMPLER

- ◆ **FULL VISUAL AVIATION FUEL CHECKING IN A CLOSED SYSTEM.**
- ◆ **NO FUEL SPILLAGE.**
- ◆ **EASY DETECTION OF DIRT AND WATER .**
- ◆ **NO SAMPLE CONTAMINATION.**
- ◆ **EASY TO CLEAN.**
- ◆ **DIRECT DRAINAGE UNDER GRAVITY.**
- ◆ **WATER DETECTION, DENSITY AND TEMPERATURE CHECKING OPTIONS.**



Introduction.

The accepted method of checking the cleanliness of aviation fuel is the 'clear and bright' test, where fuel is swirled around in an open bucket or clear glass jar and visually inspected. However, this procedure carries the risk of sample contamination from the elements or from dirty sample points. There is also a high probability of fuel spillage and contact with operations staff, which is unacceptable. The Aljac Closed Circuit Sampler (CCS) has been developed to overcome these problems and actually improves sampling procedures, and as a result it is now in widespread use with refuelling companies all over the world.

Description and Operation.

The Aljac CCS consists of a clear glass tube fitted to a white epoxy coated conical base to assist in the detection of dirt and water, and with a hinged vented cover. The base incorporates a tangential inlet port to promote vortexing of the incoming fuel, and a close coupled Stainless Steel drain valve. The inlet port should be connected to the sample points using small bore tubing (typically 10mm diameter), and we recommend fitting spring close inlet valves close to the CCS to control the filling operation, which we can also supply. The drain port should be

connected into the hydrant dispenser dump tank, depot product recovery system, or storage tank using 20mm inside diameter pipework. It is recommended that the CCS is located such that gravity drainage is possible. If not, we are able to supply a rotary pump and non return valve to drain the CCS.

When fuel is drawn into the CCS under pressure from the sample points the tangential inlet port promotes vortexing of the incoming fuel. This concentrates any contamination in the centre of the base, making detection very easy. After the fuel has been visually inspected the drain valve is opened to release the sample. Internal cleaning of the Aljac CCS is easily accomplished through the hinged lid.

A number of options are also available. Hydrometer and thermometer pockets for density and temperature checks can be provided in conjunction with a removeable inner lid. It is also possible to carry out the Shell Water Detector or Exxon Hydrokit test on the fuel sample using an option which can either be fitted to the inner lid (internal), or to a self sealing valve in the inlet port (external). The Aljac CCS is available with BSPP or NPT threads.

The Capsule Catcher.

Our Sampler is fitted with a new combined Capsule Catcher and ball inside the drain valve. It prevents any SWD capsules which have been inadvertently dropped into the sampler from passing into the drain pipework. It does so without disrupting the vortex flow pattern of fuel entering the sampler, and also allows the sampler internals to be easily cleaned. The old style Capsule Catcher is still available and can be retro fitted to existing Aljac Samplers with the old ball design.



Old style Capsule Catcher for retro fit to existing Aljac Samplers
Part No. 6007233264.

Options.

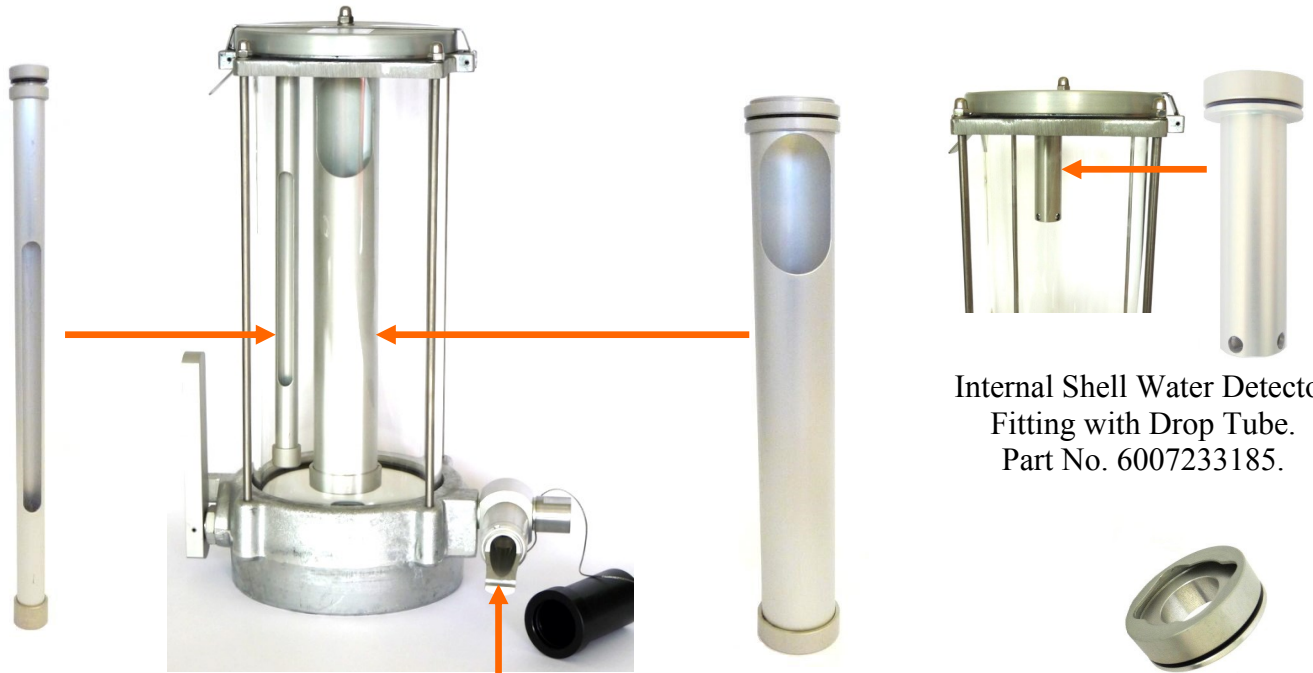

Thermometer Tube.
Part No. 6007233167.

External SWD Fitting. Part No. 60072331212 or 6007233213

Hydrometer Tube. Part No. 6007233166.

Internal Shell Water Detector Fitting with Drop Tube. Part No. 6007233185.

Internal Shell Water Detector Fitting. Part No. 6007233168.

External SWD Fitting Operation.

The External SWD fitting was designed to allow the SWD test to be carried out without opening the sampler lid and so exposing the fuel sample to possible contamination. The External SWD is fitted to the inlet connection of the sampler and incorporates a piston valve. When the assembled syringe/capsule is inserted into the External SWD Fitting the action of doing so causes the front edge of the capsule to push open the piston valve, and allows fuel to flow to the capsule, as shown below. The syringe can be operated as normal to draw fuel through the capsule.

External Shell Water Detector Fitting. Part No. 6007233212 (BSPP) or 6007233213 (NPT)

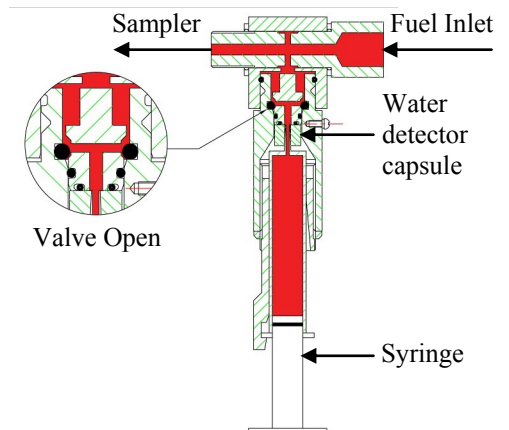
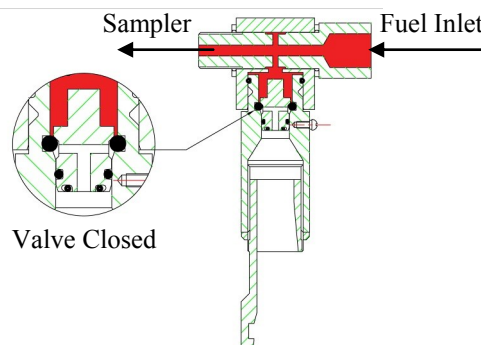

General Arrangement Drawing.

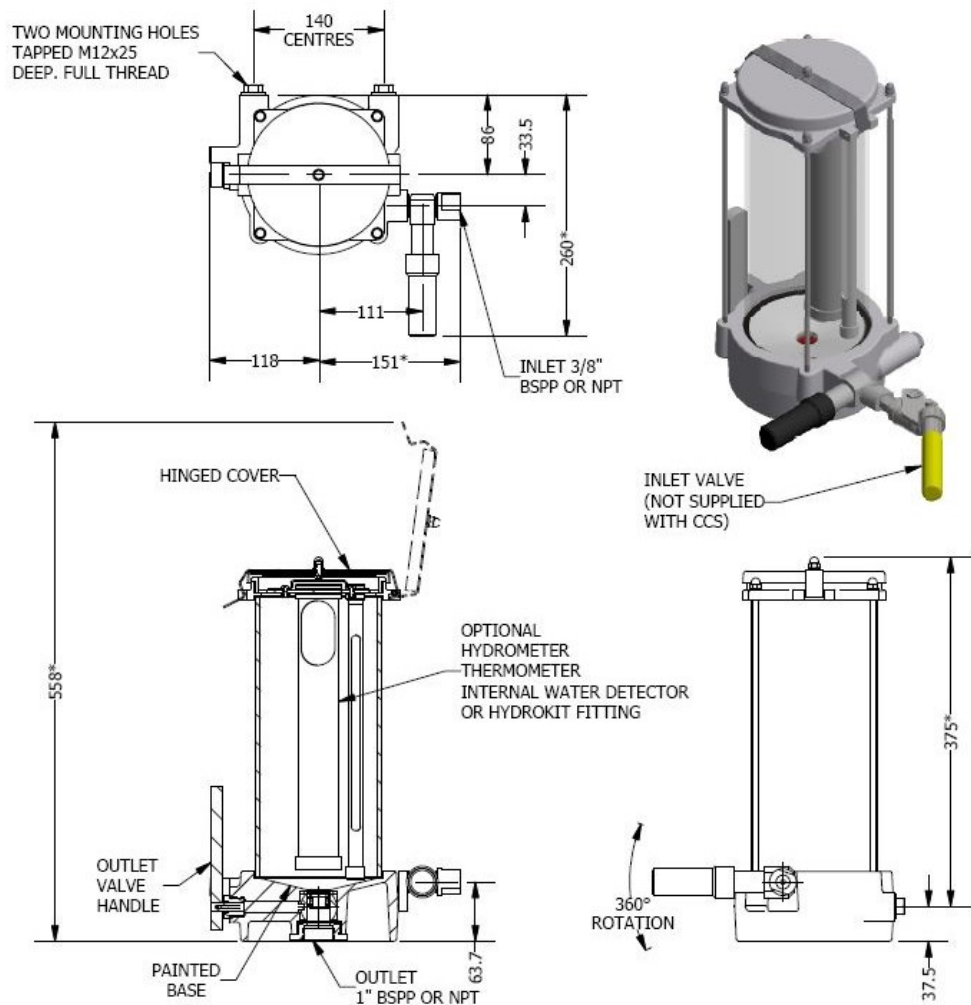

ALJAC CLOSED CIRCUIT SAMPLER (CCS)

(DIMENSIONS SHOWN THUS * ARE APPROXIMATE ONLY)

Detailed Specification.

Working Capacity: 4 Litres.

Materials: Borosilicate glass tube, cast Aluminium base and upper section, base white epoxy lined internally.

Connections: Inlet 3/8" BSPP or NPT female threaded, outlet 1" BSPP or NPT female threaded, **Mounting Holes:** M12 female threaded.

Overall Dimensions: 412 mm high (lid closed), 269 mm wide (with SWD fitting), 260 mm deep.

Nett Weight: 5 Kg (empty).

Standards.

The equipment has been subjected to a full risk assessment which included the requirements of the EC directives and harmonised standards. In accordance with European legislation, it has been concluded that the equipment should not carry a CE mark.

How To Order.

Contact our Sales Department and quote the part number.

Description	Part Number BSPP threads	Part Number NPT threads
Basic Model	6007233001	6007233021
Basic Model +Internal Velcon Hydrokit Fitting	6007233002	6007233026
Basic Model + Internal Shell Water Detector Fitting	6007233003	6007233025
Basic Model + Internal Velcon Hydrokit Fitting + Hydrometer and Thermometer Tubes	6007233004	6007233024
Basic Model + Internal Shell Water Detector Fitting + Hydrometer and Thermometer Tubes	6007233005	6007233022
Basic Model + Hydrometer and Thermometer Tubes	6007233016	6007233023
Adds External Shell Water Detector Fitting	6007233212	6007233213
Adds External Velcon Hydrokit Fitting	6007233203	6007233204
Capsule Catcher for retro fit	6007233264	6007233264
Adds 3/8" Apollo Spring Close Fill Valve	06076502P01	0607650201

Blank page